

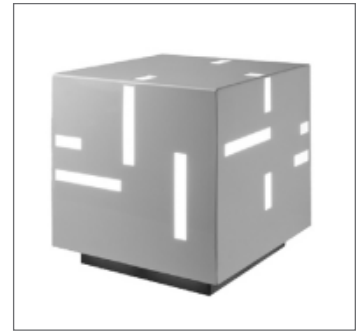

**INSTRUCTIONS PERTAINING TO RISK OF FIRE OR INJURY TO PERSONS. READ ALL INSTRUCTIONS. IMPORTANT SAFETY INSTRUCTIONS. SAVE THESE INSTRUCTIONS.**

**DANGER - RISK OF SHOCK - DISCONNECT POWER BEFORE INSTALLATION! Please read all instructions before installation.**

- Keep these instructions for future reference.
- Must be installed by a qualified electrician in accordance with national and local standards. Designplan is not responsible for fixtures installed without regard to these standards.
- The main power connection must be in accordance with local electrical codes.
- Unauthorized alterations or tampering of product voids warranty.
- Suitable for OUTDOOR applications.



### Electrical Connections:

- LED lights must be **connected in parallel** respecting polarities.
- **CHOOSE POWER SUPPLY ACCORDINGLY.** Please consider the voltage through which fixtures are fed as well as the max power consumption.
- **Connect power only if all the fixtures are connected.**
- The power supplies **MUST** be installed in aerated rooms, far from heat sources. Overloading or lack of air circulation will not permit natural dissipation.
- Use only Class 2 type electronic power supply.
- Never use switches on secondary circuit.

**ATTENTION: For Surface**- It is the contractor's responsibility to caulk around all the edges between the fixture and the mounting surface to satisfy wet label requirements. Contractor **MUST** use gel-filled wire nuts.

### Maintenance

Scheduled maintenance must be carried out once a year on all lighting devices, regardless of appliance class and type of use. It must include the following operations:

- Periodically clean fixtures to remove dirt from gratings and screw heads.
- Check tightness of screws on various parts of the device.
- Check that all cable glands and cables are intact and tight. Check that the glass or plastic lens is intact, and replace it if broken or damaged.
- The internal components such as the ballast, driver, washers and screws must not show clear signs of oxidation or rust. Clear traces of rust and oxidation will indicate the presence of water inside the device.
- In the case of damage, the components must be replaced by original components or spare parts.

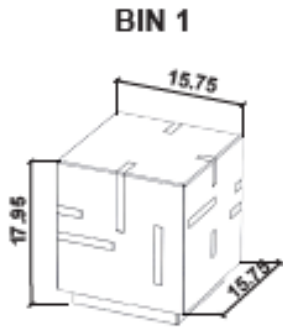

15.75 x 15.75 x H17.95in

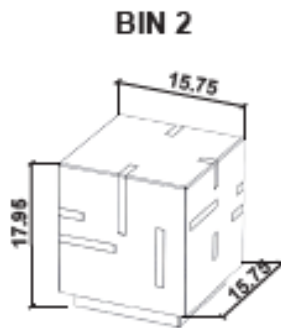

15.75 x 15.75 x H17.95in

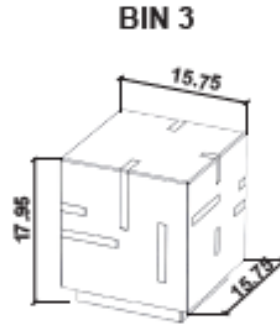

15.75 x 15.75 x H17.95in

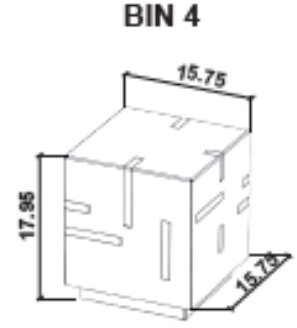

15.75 x 15.75 x H17.95in

### ACCESSORIES

ANCHOR PLATE

CODE

SIZE

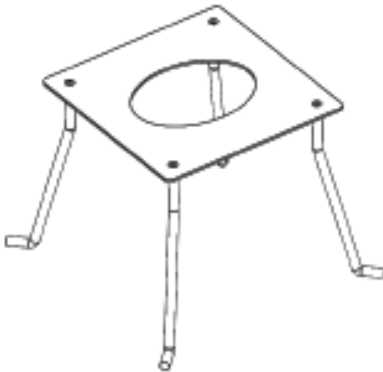

20.100379

12.6in x 12.6in x H9.84in

Model	Code	Lamp	Lumens	
			3000 K	4000 K
BIN 1 luce/light	05.101227	LED 23-3 W	2815	2925
BIN 2 luce + audio/light + audio	05.101228	LED 23-3 W	2815	2925
BIN 3 luce + Wi-Fi/light + Wi-Fi	05.101229	LED 23-3 W	2815	2925
BIN 1 luce + audio + Wi-Fi/light + audio + Wi-Fi	05.101230	LED 23-3 W	2815	2925

Phase 1 - Installation of fixing plate to the ground

Method 1 - Installation by anchor plate

1

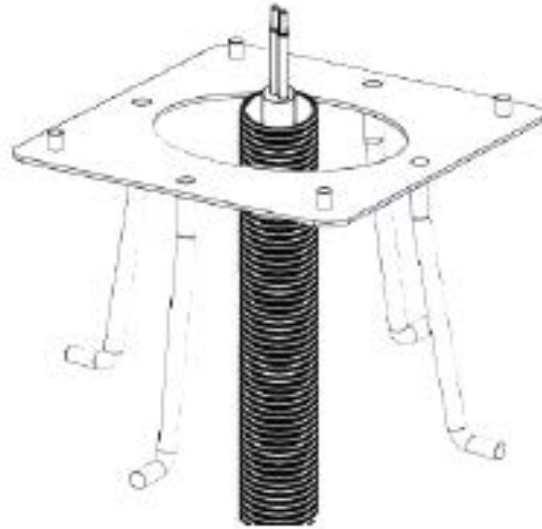

2

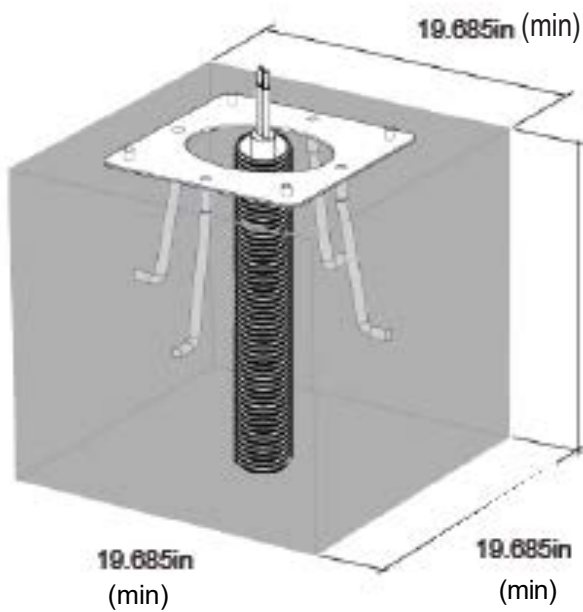

3

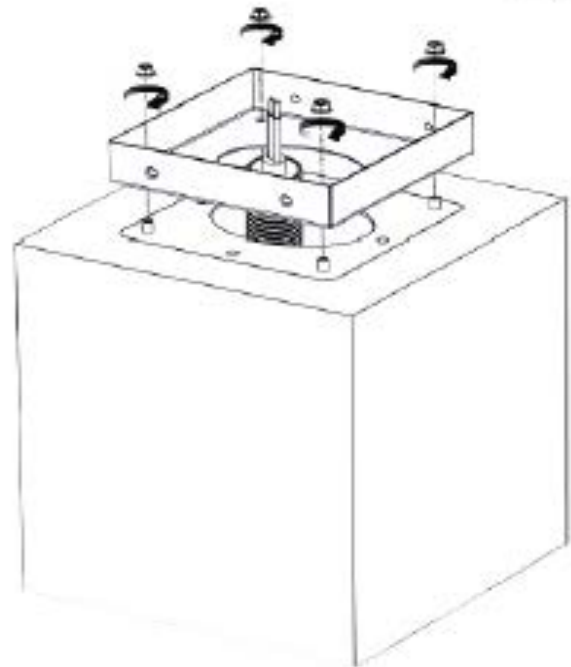

- Method 2 - Fixing directly onto the surface

1

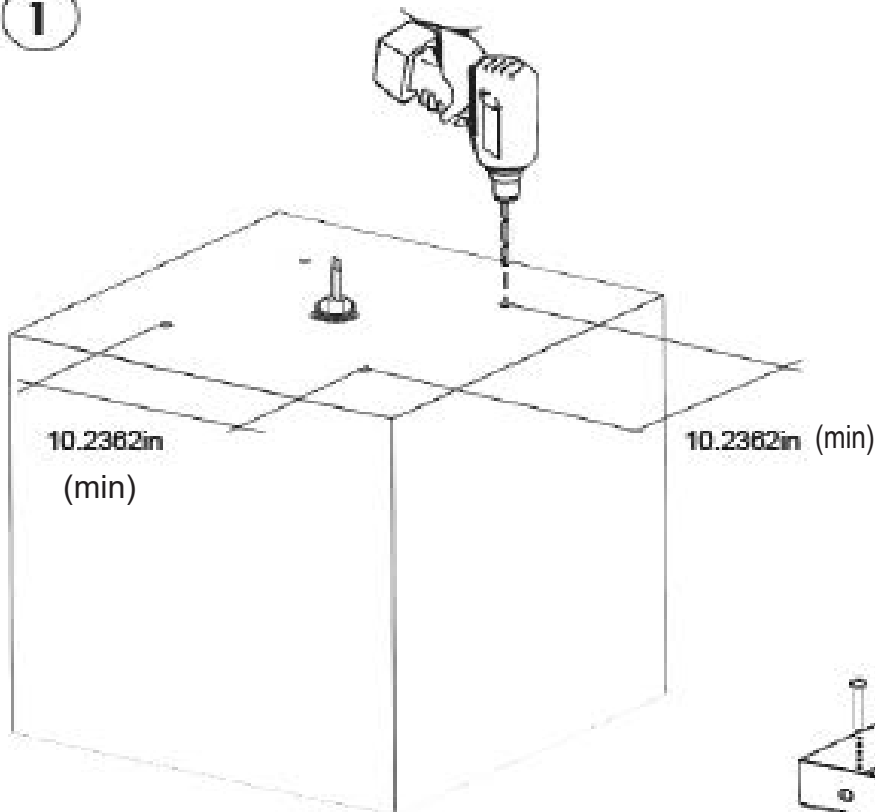

2

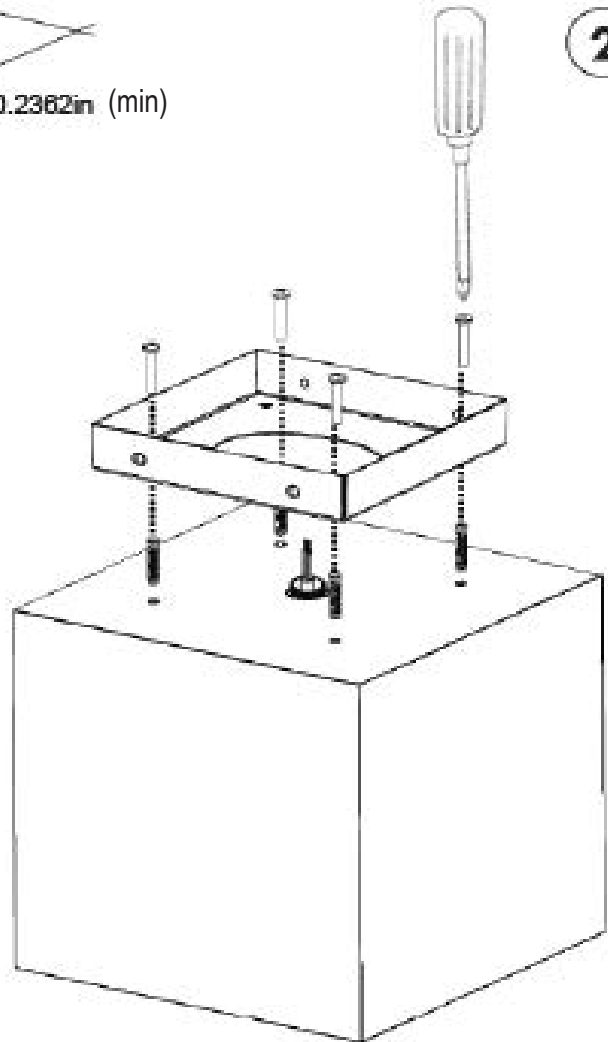

Remove the bottom of the appliance and carry out the wiring according to the model

1

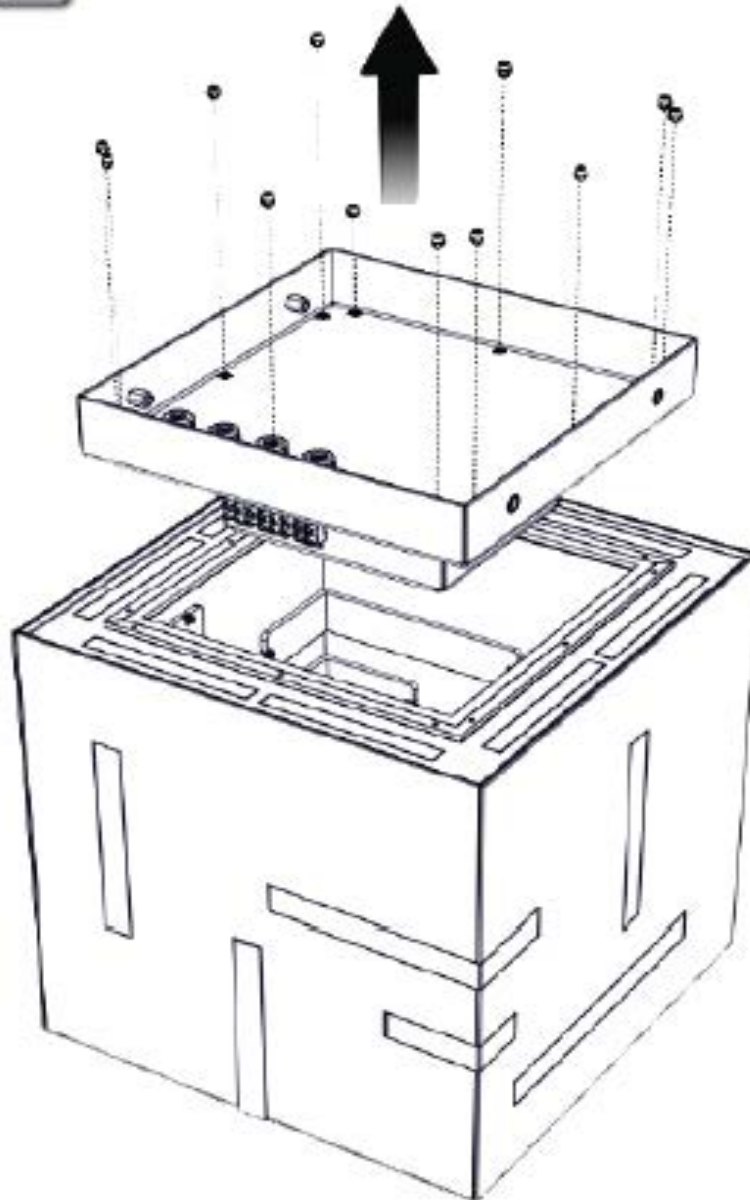

3

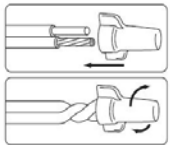
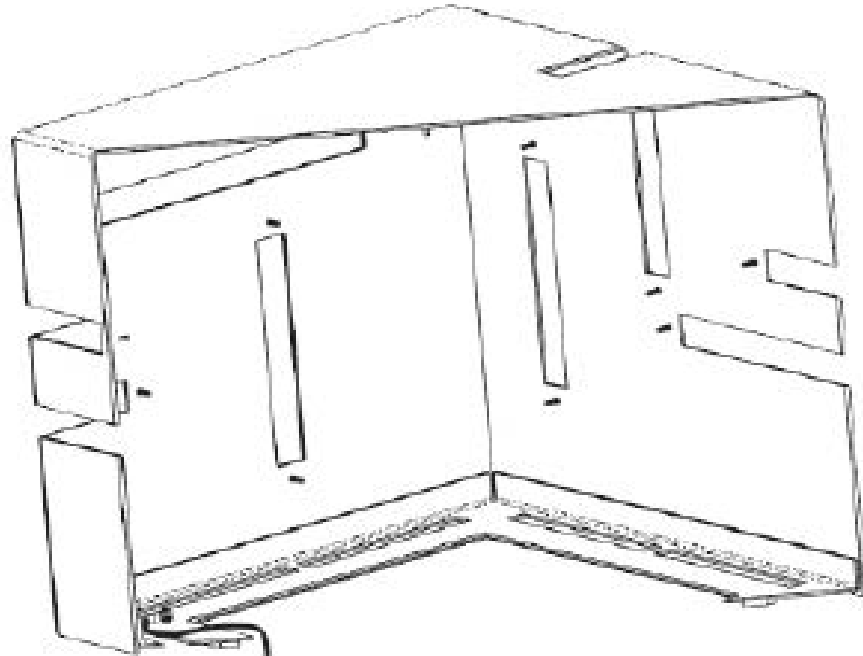

- Use gel-filled waterproof wire-nuts for wire connections.

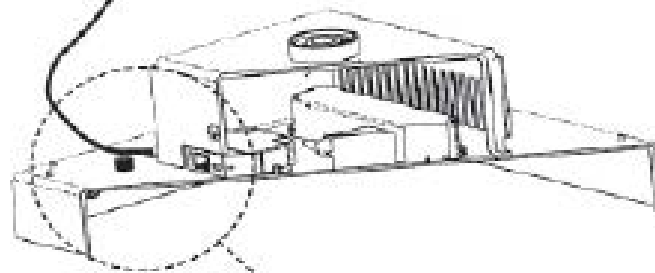

Connection of ground cable

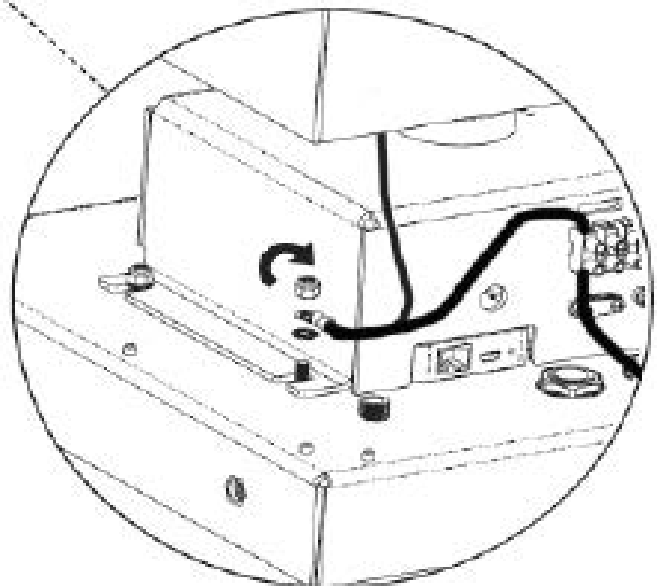

Closing and fixing

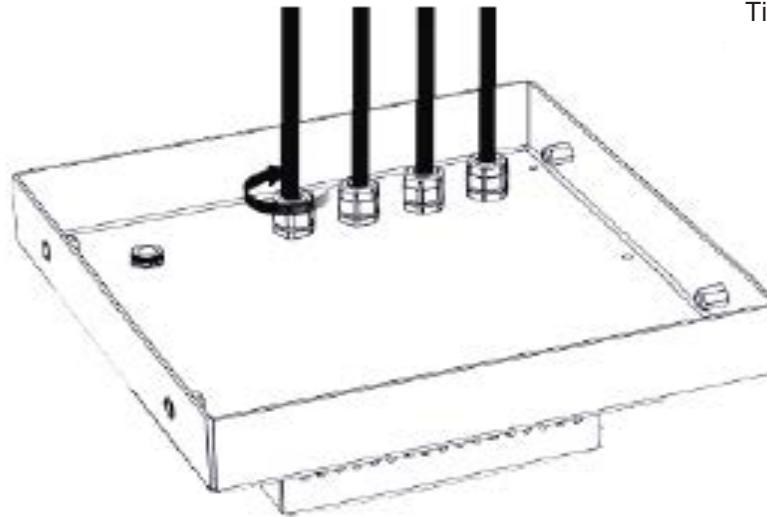

Tighten the cable glands



Do not cut the gasket

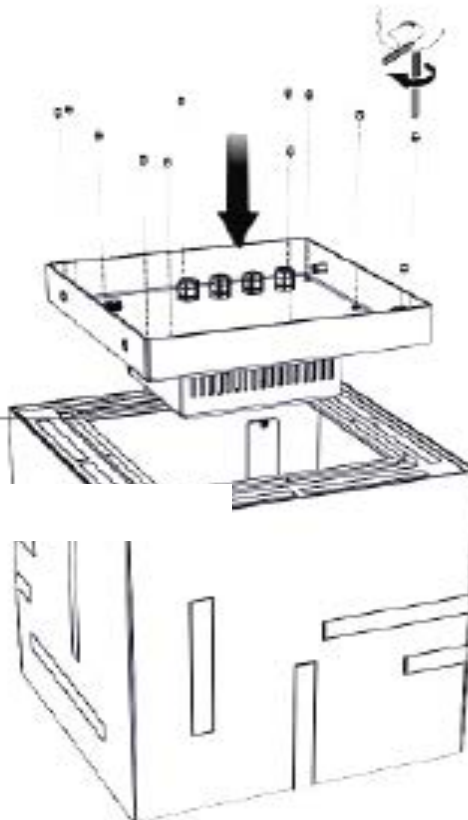

3

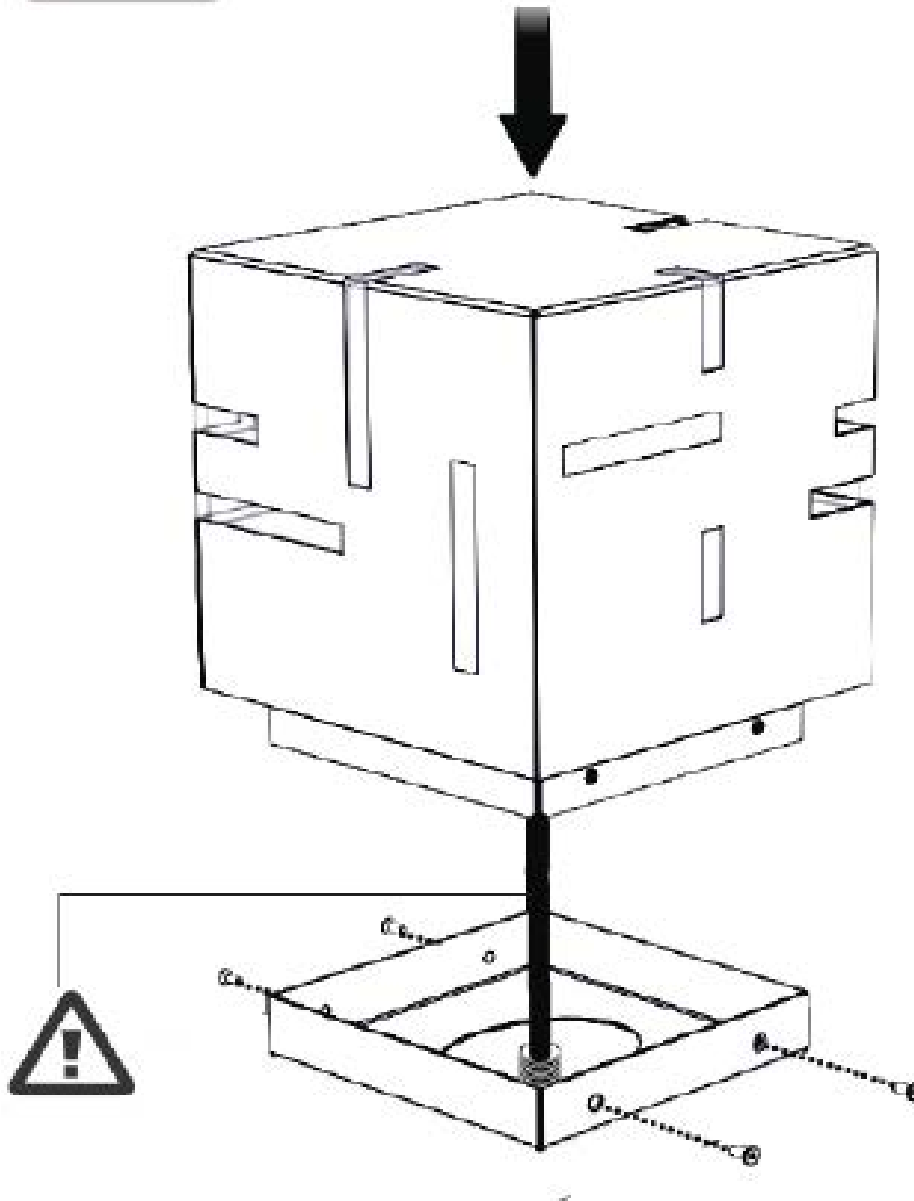



## Wiring Diagram

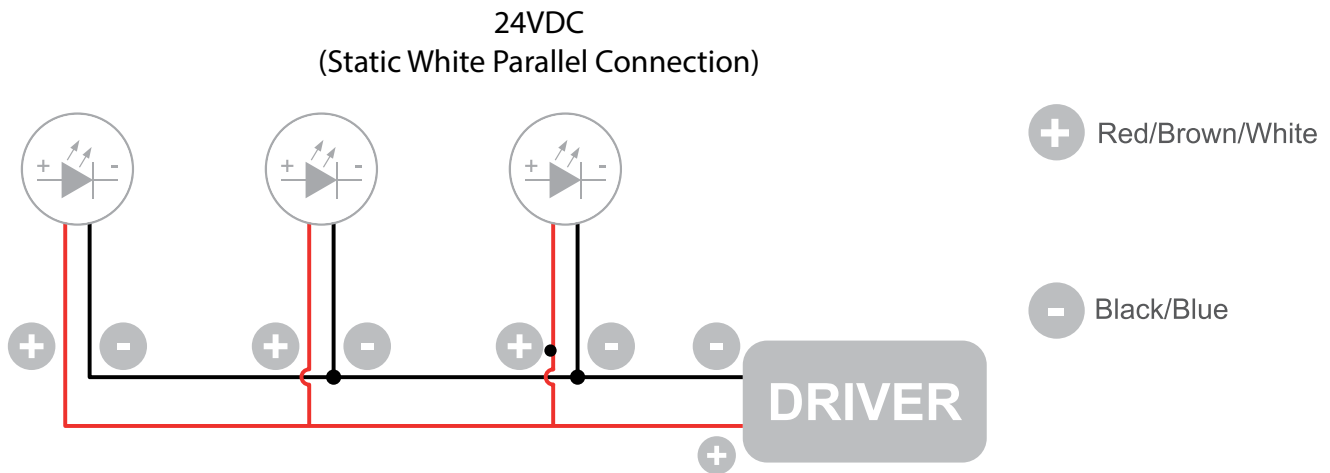

The individual lamps must be connected in parallel. Only power up the system once all the lamps have being connected.

- Only power up the system once all the lamps are connected. Connecting an individual lamp to an active power supply may cause the lamp to break due to over-voltage.
- Lamps and power supply units must be installed in well ventilated boxes or locations to allow a natural heat diffusion and avoid the devices overheating.
- On the power system, install a surge protection device to reduce the intensity of any voltage spikes to protect the lighting fixtures from the risk of damage.
- Fixture NOT suitable for covering with thermally insulating material.