



INSTRUCTIONS PERTAINING TO RISK OF FIRE OR INJURY TO PERSONS. READ ALL INSTRUCTIONS. IMPORTANT SAFETY INSTRUCTIONS. SAVE THESE INSTRUCTIONS.

DANGER - RISK OF SHOCK - DISCONNECT POWER BEFORE INSTALLATION! Please read all instructions before installation.

- Keep these instructions for future reference.
- Must be installed by a qualified electrician in accordance with national and local standards. Designplan is not responsible for fixtures installed without regard to these standards.
- The main power connection must be in accordance with local electrical codes.
- Unauthorized alterations or tampering of product voids warranty.
- Suitable for OUTDOOR applications.



ATTENTION: For In-Grade - It is the contractor's responsibility to seal the conduit with "Great Stuff" aerosol seal that prevents water and moisture penetration for ultimate protection. Contractor **MUST** use gel-filled wire nuts.

Maintenance

Scheduled maintenance must be carried out once a year on all lighting devices, regardless of appliance class and type of use. It must include the following operations:

- Periodically clean fixtures to remove dirt from gratings and screw heads.
- Check tightness of screws on various parts of the device.
- Check that all cable glands and cables are intact and tight. Check that the glass or plastic lens is intact, and replace it if broken or damaged.
- The internal components such as the ballast, driver, washers and screws must not show clear signs of oxidation or rust. Clear traces of rust and oxidation will indicate the presence of water inside the device.
- In the case of damage, the components must be replaced by original components or spare parts.

Notes

- This model is designed for concrete pour installation. The upper edge of the housing must be flush with the prepared surface into which it is recessed. Do not install fixture in a manner that creates a pocket where water can sit on top of fixture.
- Not suitable for use in places where the luminaire is likely to be exposed to a horizontal stress load caused by braking, acceleration or change of direction.

Fixture Installation

- Lighting fixture comes fully assembled. Note: When not working on fixture replace trim ring for site safety and to protect fixture components from moisture and damage. Keep each trim ring with the original body it was supplied on. Note: Use care to protect O-ring on trim ring. Do not remove, loosen, cut, deform or otherwise disturb O-ring. Keep O-ring clean and dry.
- Set fixture in desired location. Position the fixture in such a manner that the conduit/cable is not stressed at the entry point to the light fixture.
- The foundation on which the luminaire is to be installed must correspond to the maximum permissible pressure load of the luminaire. Suitable drainage must also be provided. Level the body in two horizontal planes using the three leveling tabs around outer body. The upper edge of the housing must be flush with the prepared surface into which it is recessed. **UNDER NO CIRCUMSTANCES MAY IT BE LOWER!**
- Unthread lens assembly from body with tool provided. Ensure that all internal surfaces of the fixture are kept completely dry during installation. Pry out the accessory gasket (if applicable) by using a screw driver.
- Remove (2) Flared Collar Knurled Head Thumb screws (by hand) from left and right side.
- Remove LED assembly with heat sink from fixture.
- Use M3 wrench provided to remove (2) M5x16 Screws.
- Remove bracket assembly from fixture.
- Do proper wiring connections. Connect incoming leads to quick disconnect plug. GREEN WIRE TO "GROUND", CONNECT BLACK FIXTURE TO BLACK BUILDING WIRE AND CONNECT WHITE FIXTURE WIRE TO WHITE BUILDING WIRE. PURPLE/GRAY is +0-10v DIMMING (OPTIONAL).
- Reassemble internal components. Make sure that no wires have been damaged.
- The conduit entries must be sealed with "Dow 'Great Stuff' Gaps & Cracks" (not provided). The foam should be sprayed from inside the fixture up into the conduit. Failure by the contractor to use the Dow product could cause a void in the warranty. Replace tray with lamping. If not using through wiring, plug second conduit entry with 3/4" conduit plug. Please make sure wet label requirements are met.
- Place lens frame over fixture ensuring that there is no foreign matter between the lens frame and the body. Energize the fixture and bring luminaire to operating temperature (20 to 30min.), this will evaporate the moisture content of air to be trapped. Once operating temperature has been reached, carefully thread the trim assembly to body with tool provided.

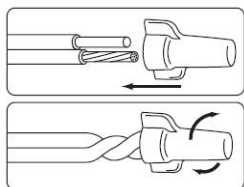

Use gel-filled waterproof wire-nuts for wire connections.

Wire Access Instructions

installation instructions

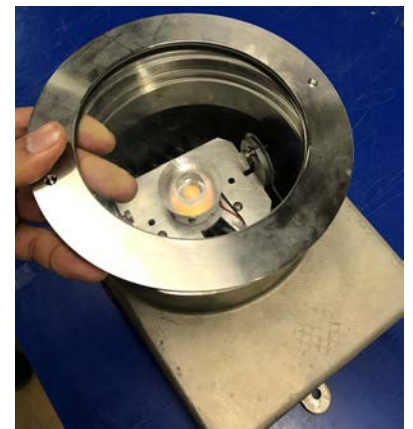
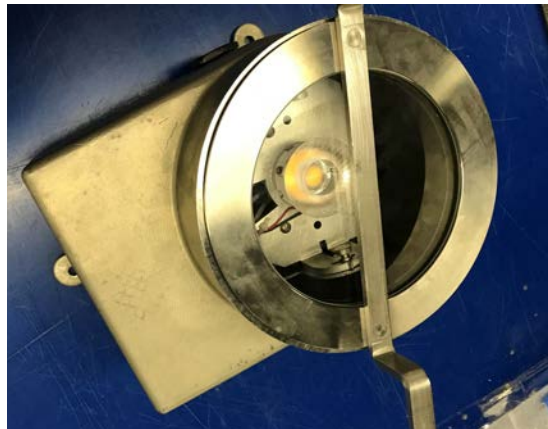
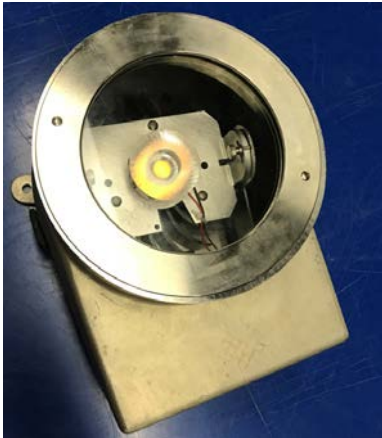

(2) Flared Collared
Knurl Head Thumb
Screws

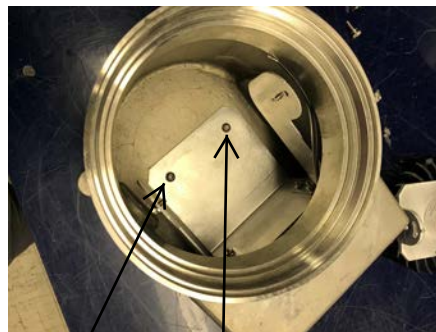

(2) M5x16 Screws

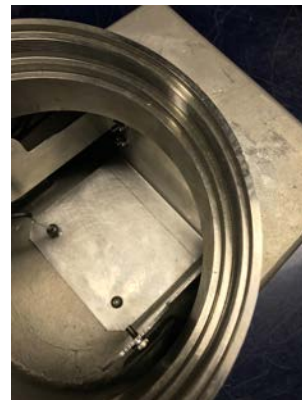

Fixture Installation

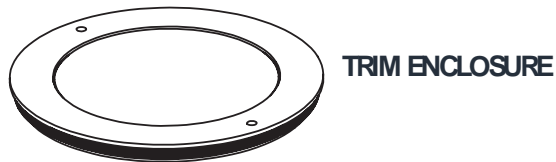

SUPPORT SCREWS

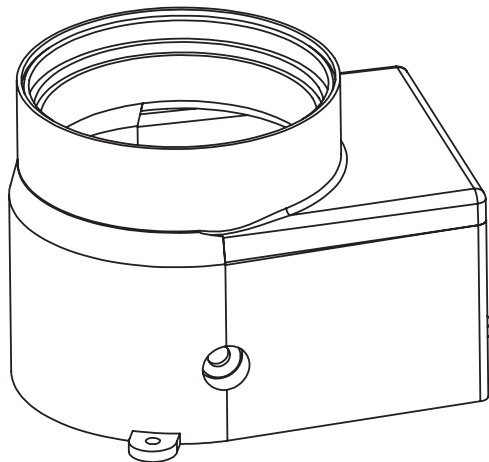
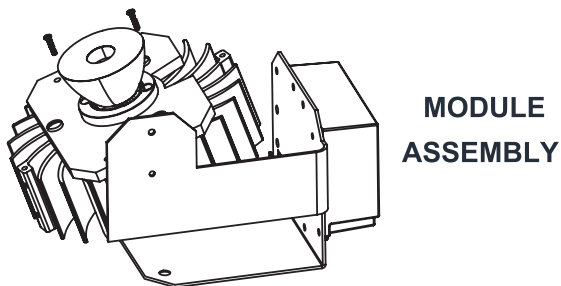

CUA COMPLETE ASSEMBLY

