



**INSTRUCTIONS PERTAINING TO RISK OF FIRE OR INJURY TO PERSONS. READ ALL INSTRUCTIONS. IMPORTANT SAFETY INSTRUCTIONS. SAVE THESE INSTRUCTIONS.**

**DANGER - RISK OF SHOCK - DISCONNECT POWER BEFORE INSTALLATION! Please read all instructions before installation.**

- Keep these instructions for future reference.
- Must be installed by a qualified electrician in accordance with national and local standards. Designplan is not responsible for fixtures installed without regard to these standards.
- Unauthorized alterations or tampering of product voids warranty.
- The main power connection must be in accordance with local electrical codes.
- Suitable for OUTDOOR applications.



**IP68, IP69K**

**ATTENTION: For In-Grade** - It is the contractor's responsibility to seal the conduit with "Great Stuff" aerosol seal that prevents water and moisture penetration for ultimate protection. Contractor **MUST** use gel-filled wire nuts.

**Maintenance**

Scheduled maintenance must be carried out once a year on all lighting devices, regardless of appliance class and type of use. It must include the following operations:

- Periodically clean fixtures to remove dirt from gratings and screw heads.
- Check tightness of screws on various parts of the device.
- Check that all cable glands and cables are intact and tight. Check that the glass or plastic lens is intact, and replace it if broken or damaged.
- The internal components such as the ballast, driver, washers and screws must not show clear signs of oxidation or rust. Clear traces of rust and oxidation will indicate the presence of water inside the device.
- In the case of damage, the components must be replaced by original components or spare parts.

**Notes**

- This fixture is designed for concrete pour installation.
- Do not install fixture in a manner that creates a pocket where water can sit on top of fixture.

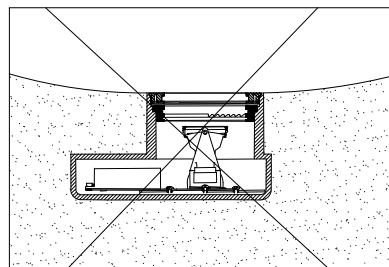
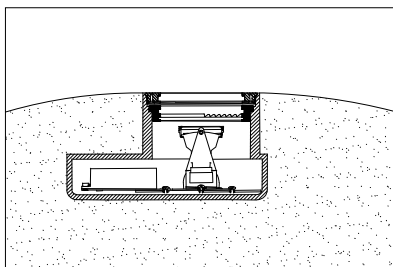

Use the holes in the feet for leveling purposes only. They are not designed for holding weight other than the fixture.

## Fixture Installation

- Remove lens frame from body by use of spanner wrench.
- Body is drilled and tapped on the sides of the body with two- (2) 3/4 NPT for conduit or IP68 liquid tight fittings depending on the job specification (not provided). Properly plug and seal using plumbers tape or equivalent to any holes that are not used. A conduit plug is supplied but not sealed. Please make sure wet label requirements are met.
- Position the fixture in such a manner that the conduit is not stressed at the entry point to the light fixture. Ensure that all internal surfaces of the luminaires are kept completely dry during installation.
- Make sure that the top surface of the body is completely flush with the finished grade when concrete is poured.

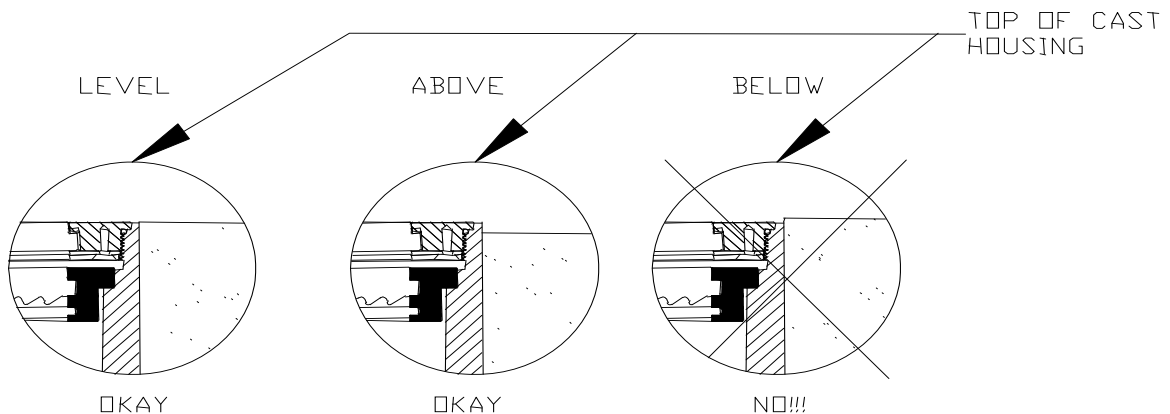

- Please remove the three 8-32 screws holding the LED assembly to body to access wire entry. Connect incoming leads to quick disconnect and ground wire. **CONNECT GREEN WIRE TO "GROUND", CONNECT BLACK FIXTURE TO BLACK BUILDING WIRE AND CONNECT WHITE FIXTURE WIRE TO WHITE BUILDING WIRE.**
- The conduit entries must be sealed with "Dow 'Great Stuff' Gaps & Cracks" or equivalent (not provided). The foam should be sprayed from inside the fixture up into the conduit. Failure by the contractor to use the Dow product could cause a void in the warranty. Install LED assembly removed in step 5.
- Place lens frame over fixture ensuring that there is no foreign matter between the lens frame and the body. Use the special spanner wrench to start threading the trim to body. Do not tighten at this point. Be certain not to cross thread. **Energize the fixture and bring luminaire to operating temperature (10 to 15min.), this will evaporate the moisture content of air to be trapped.** Once operating temperature has been reached tighten trim with spanner wrench. Note: Loose lens assembly will affect the lens frame ability to seal.

## Wire Access Instructions

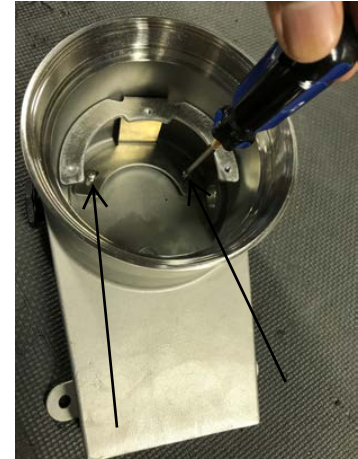
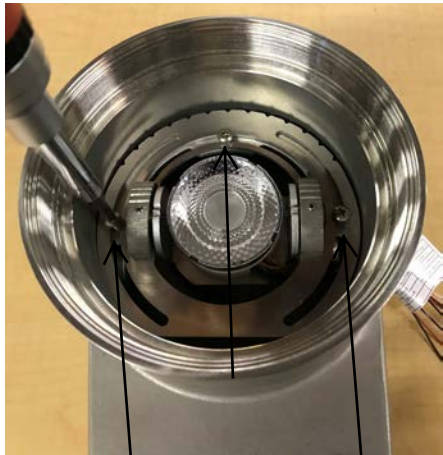

1. After taking stainless steel trim ring along with lens components from the CXA assembly, use a screw driver to remove (3) 8-32 screws from the adjustable top plate along with the LED and optics assembly.
2. Remove the adjustable top plate with the LED and optics assembly from the fixture.
3. Using a screw driver, remove the (2) 8-32 screws on the bottom support bracket.
4. Remove the bottom support bracket from the fixture to obtain access to the bottom of the fixture.
5. When finished, assemble the components back together.