



INSTRUCTIONS PERTAINING TO RISK OF FIRE OR INJURY TO PERSONS. READ ALL INSTRUCTIONS. IMPORTANT SAFETY INSTRUCTIONS. SAVE THESE INSTRUCTIONS.

DANGER - RISK OF SHOCK - DISCONNECT POWER BEFORE INSTALLATION! Please read all instructions before installation.

- Keep these instructions for future reference.
- Must be installed by a qualified electrician in accordance with national and local standards. Designplan is not responsible for fixtures installed without regard to these standards.
- The main power connection must be in accordance with local electrical codes.
- Unauthorized alterations or tampering of product voids warranty.
- Suitable for OUTDOOR applications.
- DO NOT INSTALL INSULATION WITHIN 3.0" (76 mm) OF ANY PART OF THE LUMINAIRE.



**IP65
IK08**

ATTENTION: For Surface - It is the contractor's responsibility to caulk around all the edges between the fixture and the mounting surface to satisfy wet label requirements.

Maintenance

Scheduled maintenance must be carried out once a year on all lighting devices, regardless of appliance class and type of use. It must include the following operations:

- Check that the glass or plastic lens is intact, and replace it if broken or damaged.
- Check that all cable glands and cables are intact and tightly secured.
- Check tightness of screws on various parts of the device.
- Periodically clean the fixtures to remove the built-up dirt from gratings and screw heads.
- For class II fixtures, check any plastic/insulating casings, to determine any damage to the insulation.
- Check for any water that may have collected inside the fixture or its outer casing.
- The internal components such as the ballast, transformer, driver, washers and screws must not show clear signs of oxidation or rust. Clear traces of rust and oxidation will indicate the presence of water inside the device.
- In the case of damage, the components must be replaced by original components or spare parts.

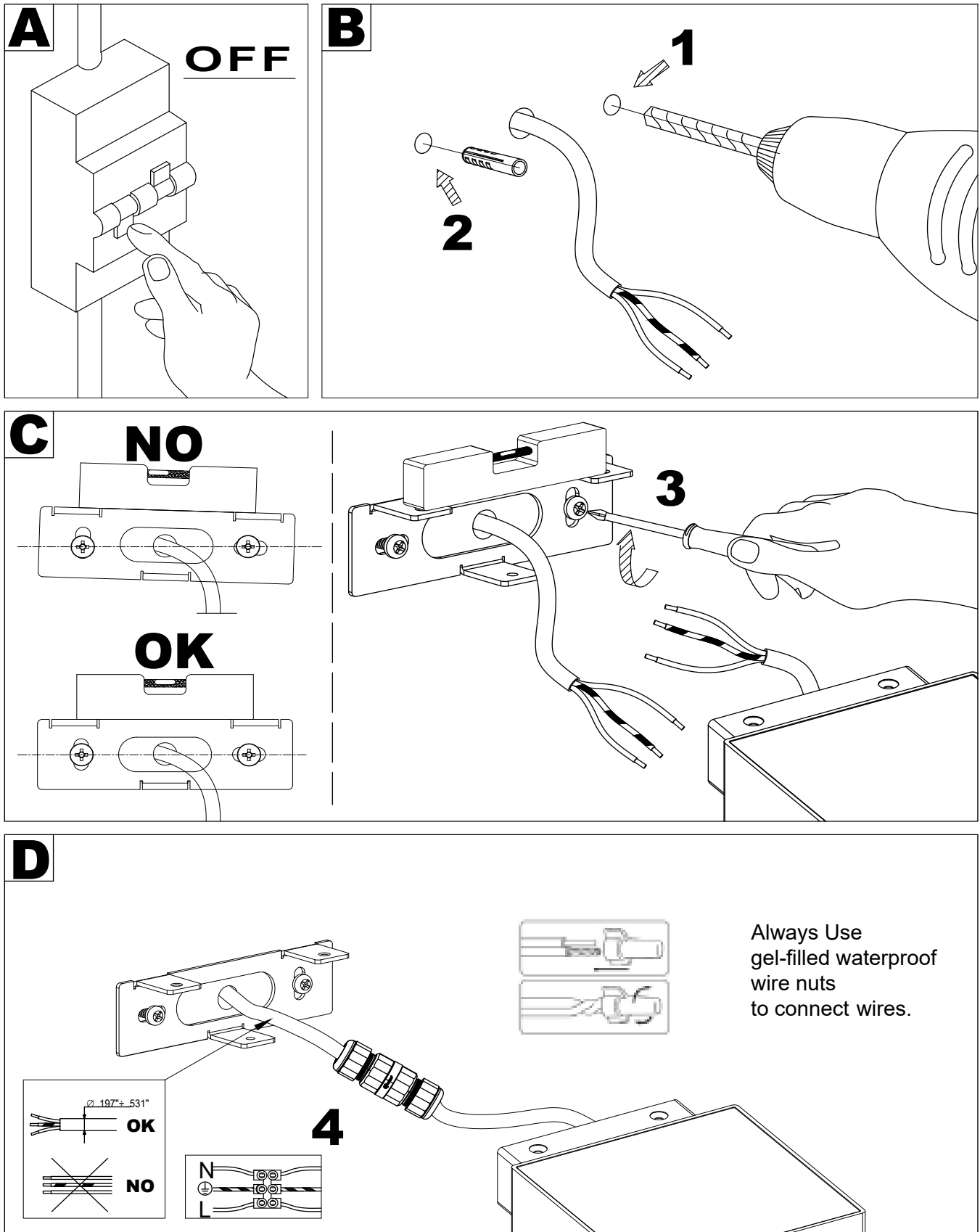

E

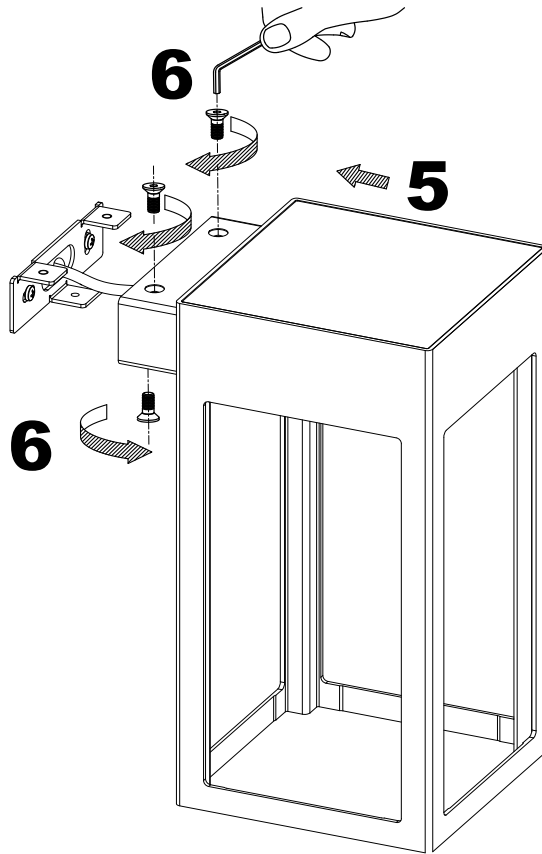

- * "Energy efficiency light source"
- * This product contains a light source with energy efficiency class: see column "Energy efficiency light source"