

Imperturbable light.

kami wall lamp

design by Landa R&D

designplan 

79 Trenton Avenue
Frenchtown, NJ 08825

www.designplan.com

Tel: (908) 996-7710
Fax: (908) 996-7042



kami

With Kami tradition and technology come together to illuminate rooms in a perfect way.

An extremely reliable, long-lasting and versatile product: a diffused natural light emitted by an opal polycarbonate screen supplied with or without grid. Precise geometry where light and shape complement each other creating an imperturbable and never invasive light beam. Available with 10 W power, the Kami die-cast aluminum body can be customized with various finishes, from white to black, for infinite aesthetic solutions.

KAMI | CEILING LAMP





kami_1

DIFFUSE

10W



TECHNICAL SPECIFICATIONS

	DIFFUSE
Source lamp	LED 10W
Total wattage	13W
Voltage	350mA, 50-60 Hz
Control	On/Off • dimmable on request
Light color	3000 K • 4000 K • other colors on request
Delivered lumens *Source lumens	570 lm (1200 lm*) @ 3000 K 610 lm (1300 lm*) @ 4000 K
Luminous efficacy	44 lm/W @ 3000 K 47 lm/W @ 4000 K
McADAM steps	3
Beam	Diffuse
CRI	> 90
Life time	L70 > 50.000 h Ta 40°C
IP rating	IP65
IK rating	IK08

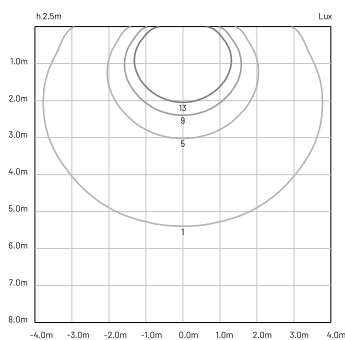
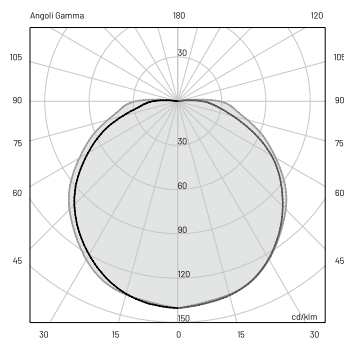

MATERIALS

Body	Die-cast aluminum EN47100
Diffuser	Opal polycarbonate
Finishing	Polyester powder paint

ORDER CODE

KA10POS D_B10_

Finishing

L	Graphite	●
H	Gray	●
V	Oxide	●
G	Black	●
U	White	○

Light color

N	4000 K
H	3000 K

Example

KA10POS DHB10L

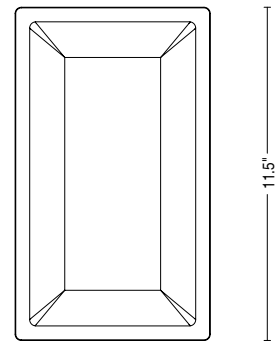
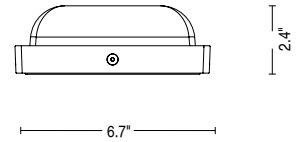

kami_2

DIFFUSE

10W



TECHNICAL SPECIFICATIONS

	DIFFUSE
Source lamp	LED 10W
Total wattage	13W
Voltage	350mA, 50-60 Hz
Control	On/Off • dimmable on request
Light color	3000K • 4000K • other colors on request
Delivered lumens *Source lumens	570 lm (1200 lm*) @ 3000 K 610 lm (1300 lm*) @ 4000 K
Luminous efficacy	44 lm/W @ 3000 K 47 lm/W @ 4000 K
McADAM steps	3
Beam	Diffuse
CRI	> 90
Life time	L70 > 50.000 h Ta 40°C
IP rating	IP65
IK rating	IK08

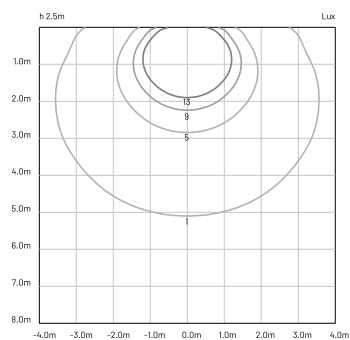
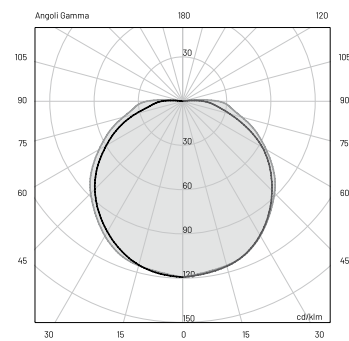

MATERIALS

Body	Die-cast aluminum EN47100
Diffuser	Opal polycarbonate
Finishing	Polyester powder paint

ORDER CODE

KA 2 0 POS D _ B 1 0 _

Finishing

L	Graphite	●
H	Gray	●
V	Oxide	●
G	Black	●
U	White	○

Light color

N	4000 K
H	3000 K

Example

KA 2 0 POS D H B 1 0 L

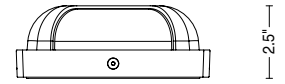

6.7"

2.5"

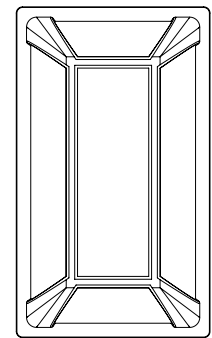

11.5"



