

LAMBDA

Direct / Indirect Pendant



An elegant and minimalist lighting solution, Lambda integrates seamlessly into office, residential or commercial environments. With a body comprised of extruded aluminum only 0.625" thick and a unique shape, Lambda offers direct / indirect light emissions, adjustable with its integral 0-10V dimming drivers.

The indirect emission on top of the luminaire offers a linear spread, while the direct emission on the bottom is diffused. Small details such as no power cord maintains the minimalistic idea without sacrificing function in the field.

Multiple color temperatures and finish options are available in various lengths.

Continuous runs available - see datasheet for connectors.



TECHNICAL DRAWING

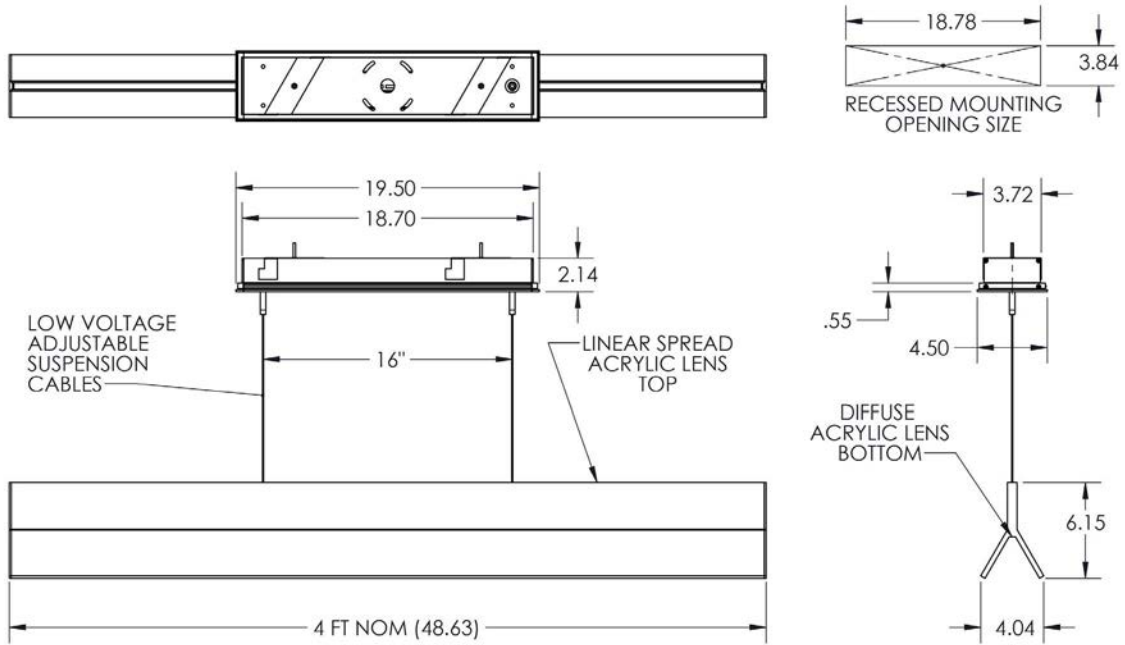

NOTES:

- CANOPY CAN BE RECESSED IN THE CEILING OR SURFACE MOUNTED OVER J-BOX CAPABLE OF SUPPORTING MIN. 50 LB

ORDERING INFORMATION

Example: LAM-L-8-30-P-10-C-SC.

LAM-L	-		-	P	-		-	
Model No.	Length	CCT	Body	Finish	Driver	Canopy		
LAM-L	4 - 4 foot	27 - 2700K	P - Pendant	02 - Black Suede	C - 120-277VAC, 0-10V Dimming	RC - Recessed*		
	6 - 6 foot	30 - 3000K		18 - Textured Bronze		SC - Surface*		
	8 - 8 foot	35 - 3500K		10 - Matte Silver	2 - 347V, 0-10V Dimming	RW - Recessed, White		
		40 - 4000K		11 - White Suede		SW - Surface, White		
				99 - Custom		AS - Surface Acoustical Tile*		
						AW - Surface Acoustical Tile, White		

* Same finish as fixture
- Other color on request -

NOTE: AS & AW utilize a rosette mounting pattern to allow direct mounting to a junction box that will hold a minimum of 50 lbs.

