



INSTRUCTIONS PERTAINING TO RISK OF FIRE OR INJURY TO PERSONS. READ ALL INSTRUCTIONS. IMPORTANT SAFETY INSTRUCTIONS. SAVE THESE INSTRUCTIONS.

DANGER - RISK OF SHOCK - DISCONNECT POWER BEFORE INSTALLATION! Please read all instructions before installation.

- Keep these instructions for future reference.
- Must be installed by a qualified electrician in accordance with national and local standards. Designplan is not responsible for fixtures installed without regard to these standards.
- Unauthorized alterations or tampering of product voids warranty.
- The main power connection must be in accordance with local electrical codes.
- Suitable for OUTDOOR applications.



Electrical Connections:

- LED lights must be **connected in parallel** respecting polarities.
- **CHOOSE POWER SUPPLY ACCORDINGLY.** Please consider the voltage through which fixtures are fed as well as the max power consumption.
- **Connect power only if all the fixtures are connected.**
- The power supplies **MUST** be installed in aerated rooms, far from heat sources. Overworking or lack of air circulation will not permit natural dissipation.
- Use only Class 2 type electronic power supply.
- Never use switches on secondary circuit.

ATTENTION: It is the contractor's responsibility to caulk around the edges between the fixture and the mounting surface, to satisfy wet label requirements.

Maintenance

Scheduled maintenance must be carried out once a year on all lighting devices, regardless of appliance class and type of use. It must include the following operations:

- Periodically clean fixtures to remove dirt from gratings and screw heads.
- Check tightness of screws on various parts of the device.
- Check that all cable glands and cables are intact and tight. Check that the glass or plastic lens is intact, and replace it if broken or damaged.
- The internal components such as the ballast, driver, washers and screws must not show clear signs of oxidation or rust. Clear traces of rust and oxidation will indicate the presence of water inside the device.
- In the case of damage, the components must be replaced by original components or spare parts.

Fixture Installation

- It is the contractor's responsibility to caulk around the edges between the fixture and the mounting surface to satisfy wet label requirements.

installation instructions

Base plate position adjustment

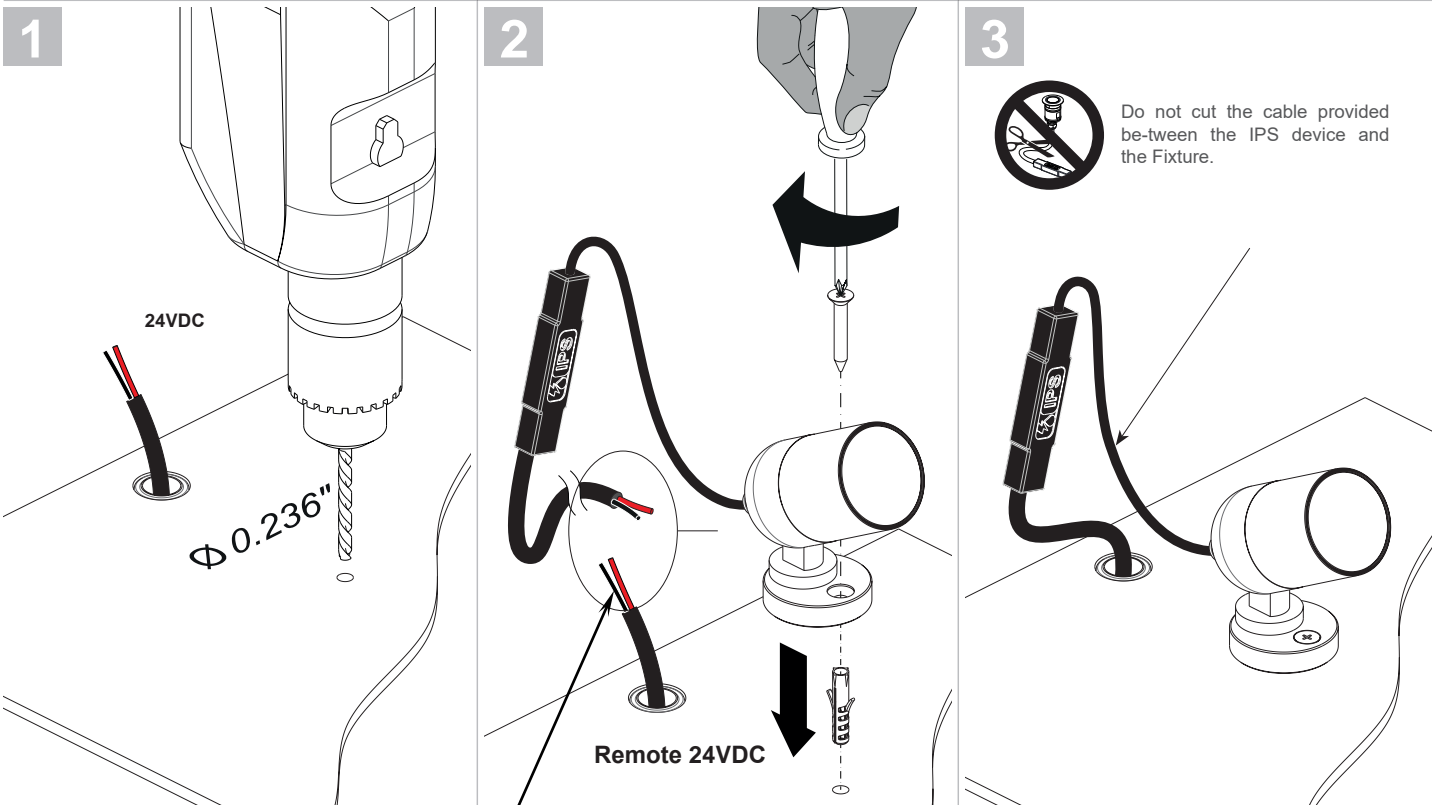
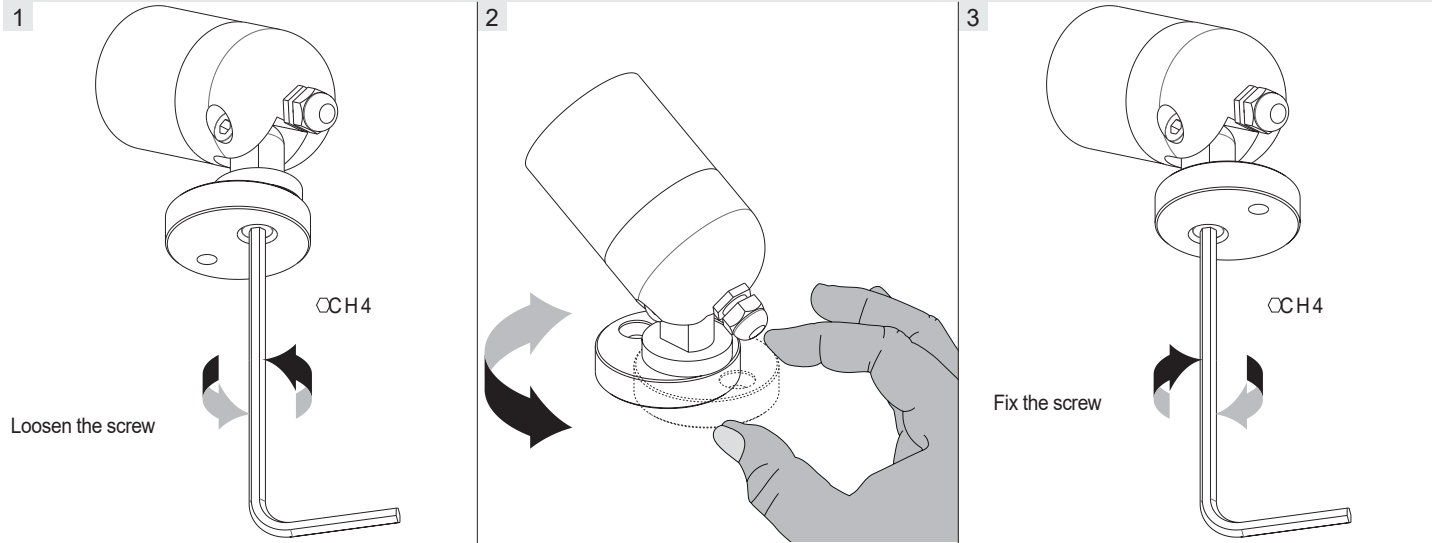

Use gel-filled waterproof wire-nuts for wire connections.

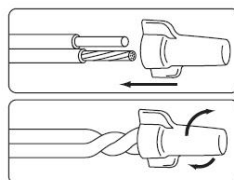

- It is the contractor's responsibility to install Remote Driver in a suitable electrical enclosure.

Fixture Installation

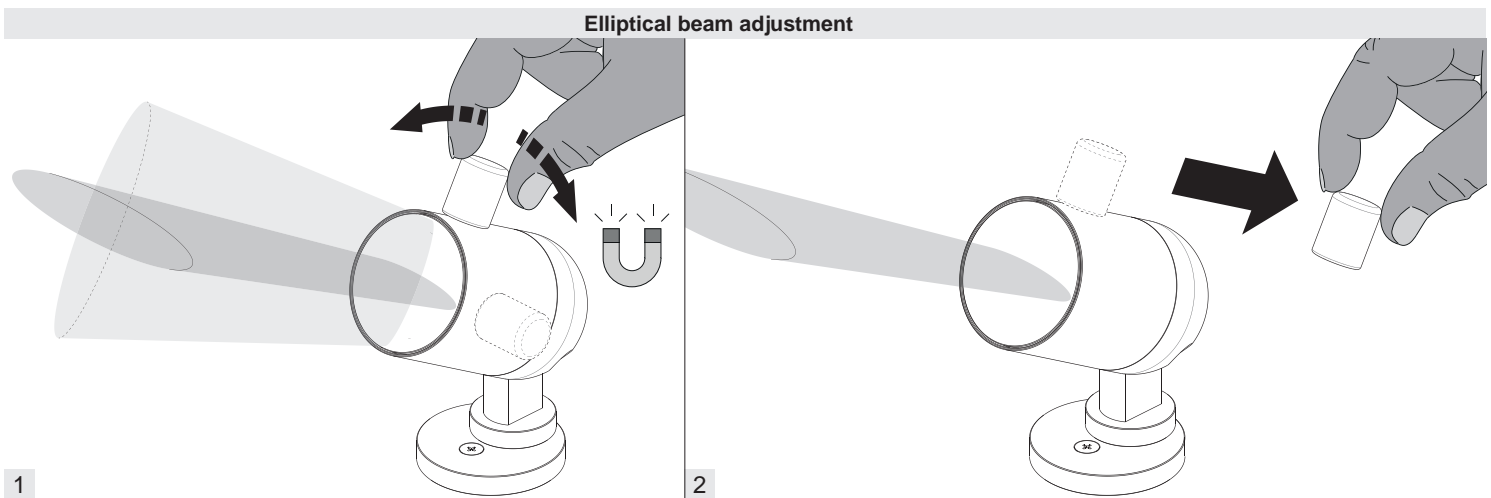
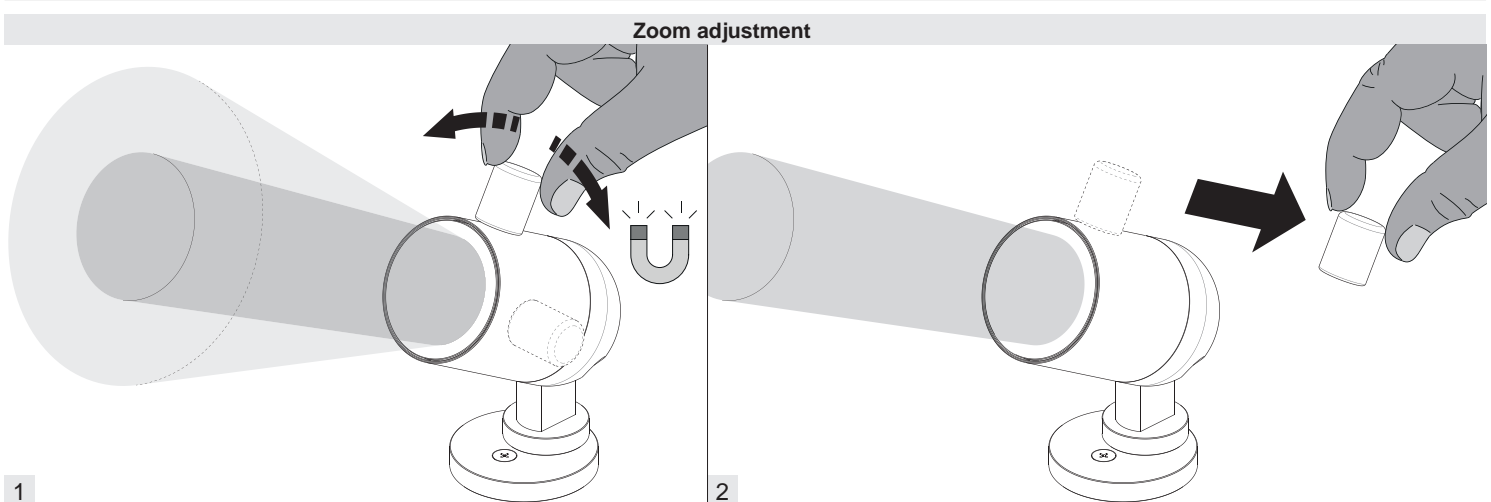
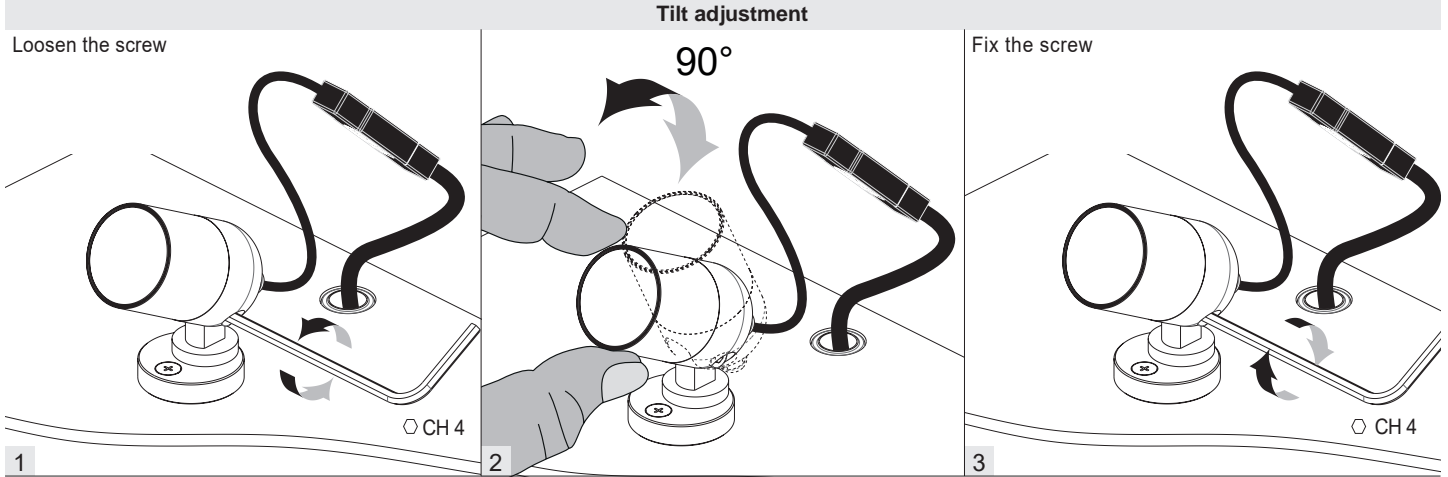

1

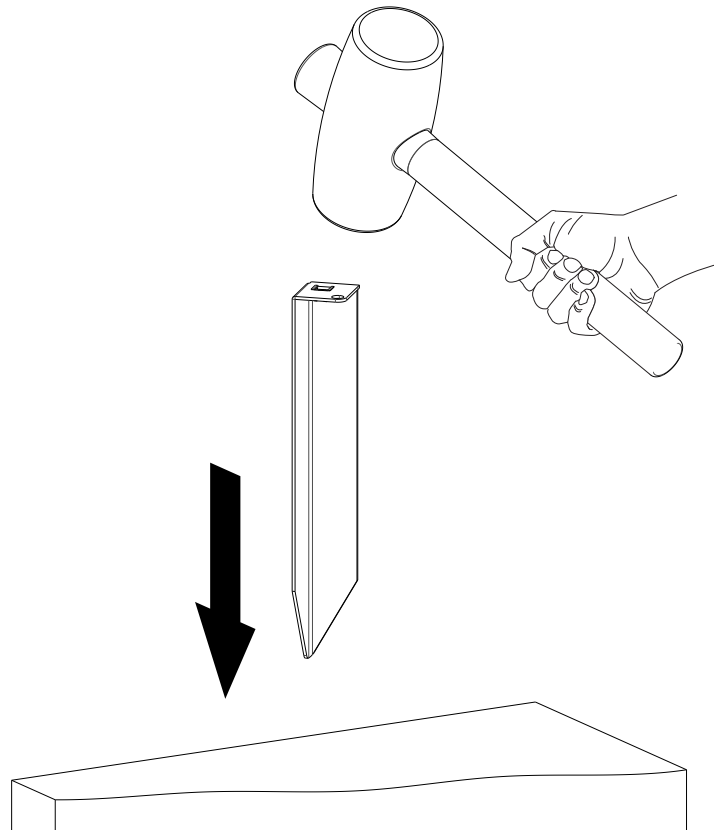

2

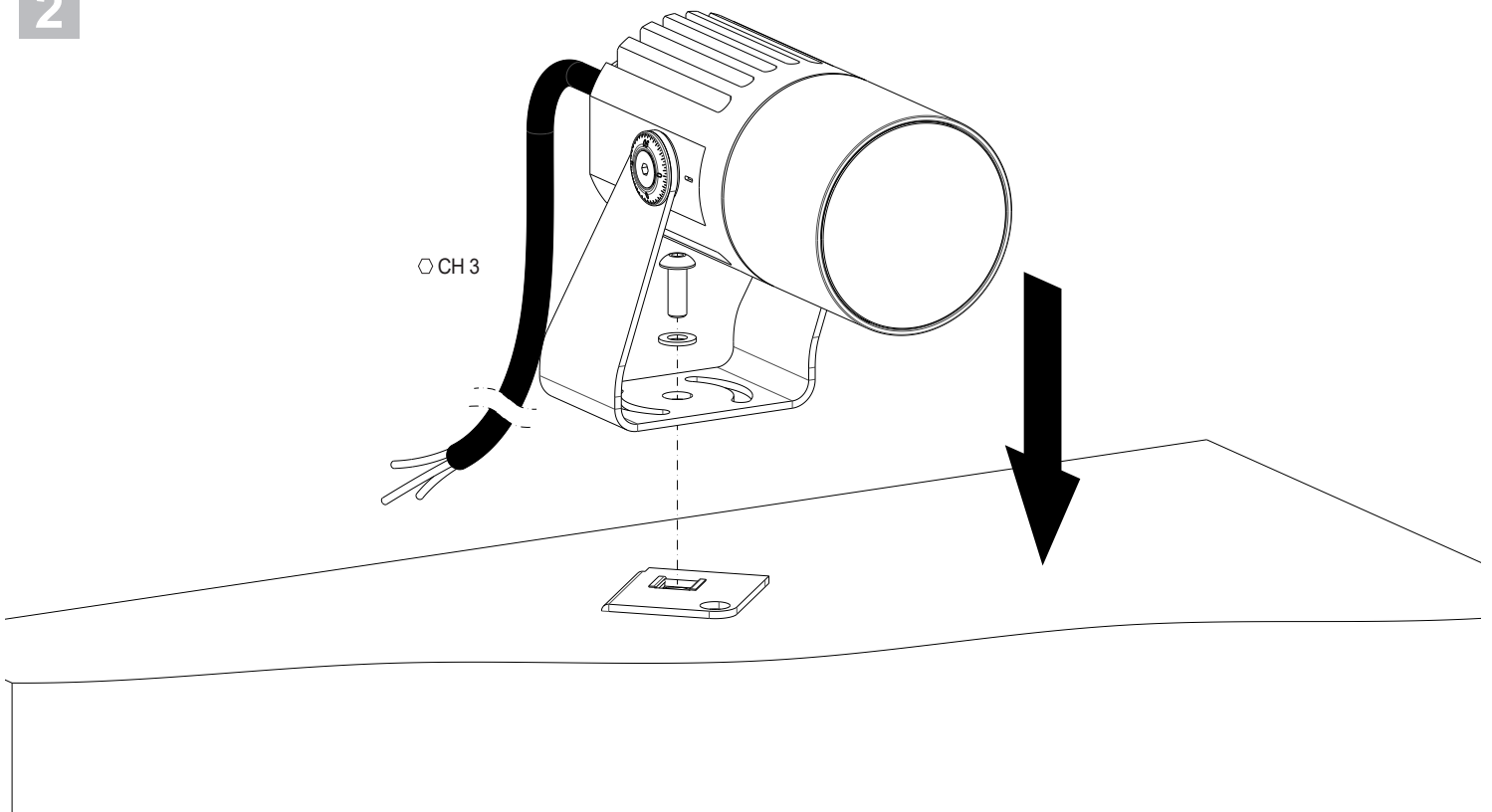

1 - WB1001

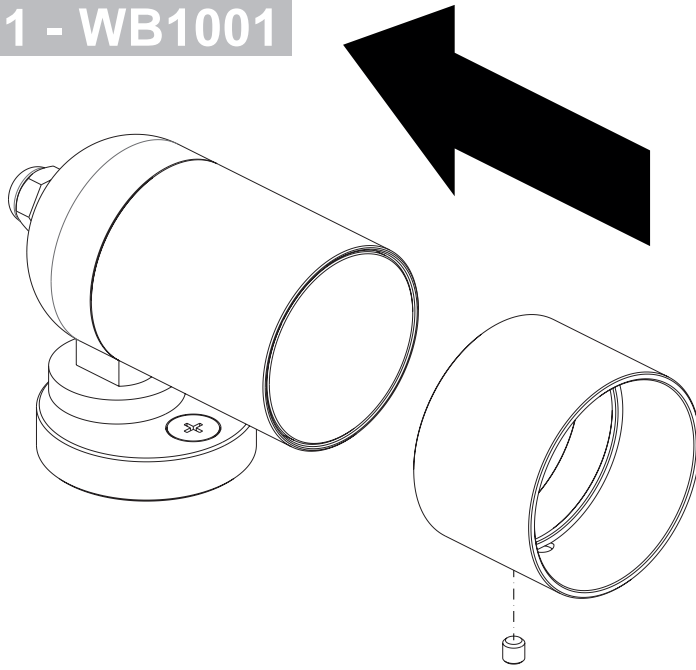

2 - WB1001

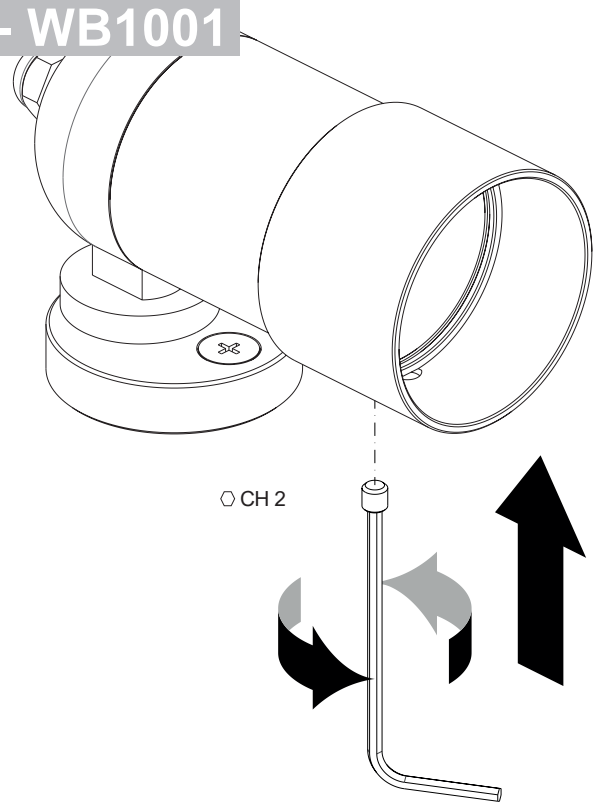

1 - WB1002

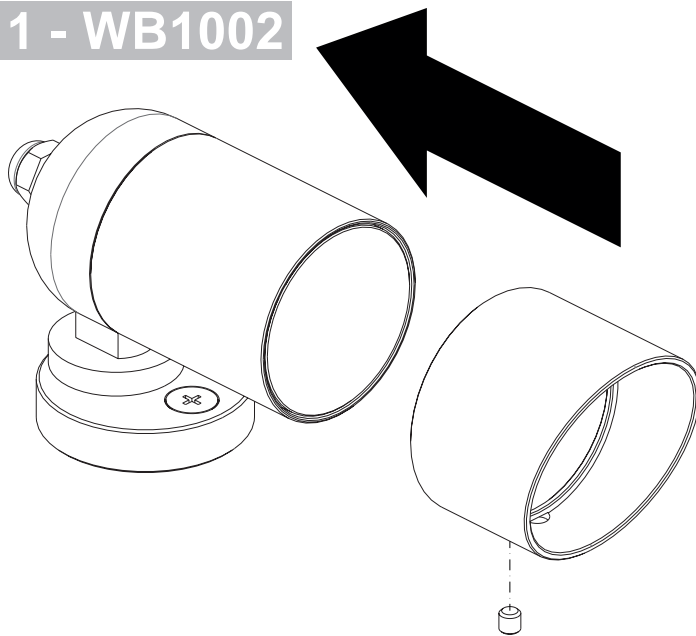

2 - WB1002

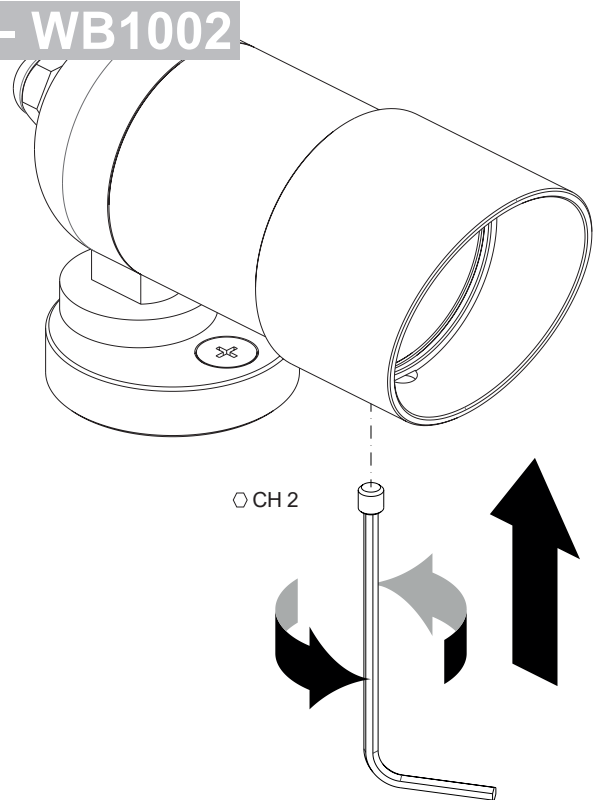

PIVOT WITH CANOPY

Accessory Installation- Mounting over J-Box (AC-00003H)

installation instructions

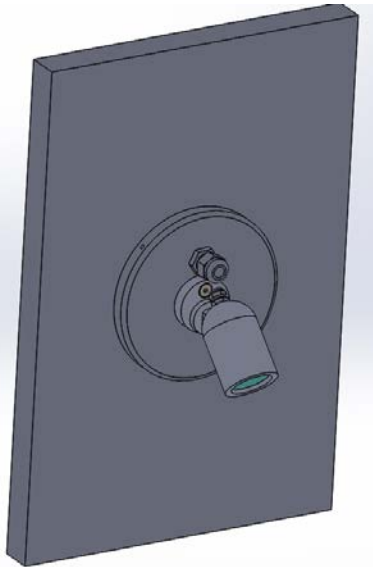

Pivot on Canopy

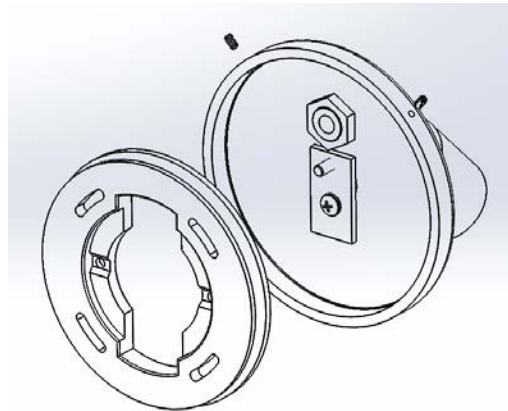

Pivot with Canopy
Exploded Back
View

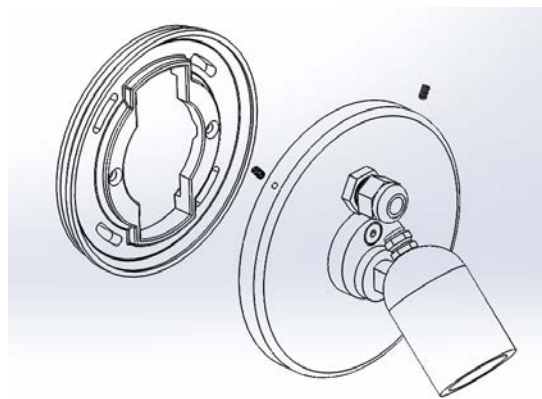

Pivot with Canopy Exploded Front View

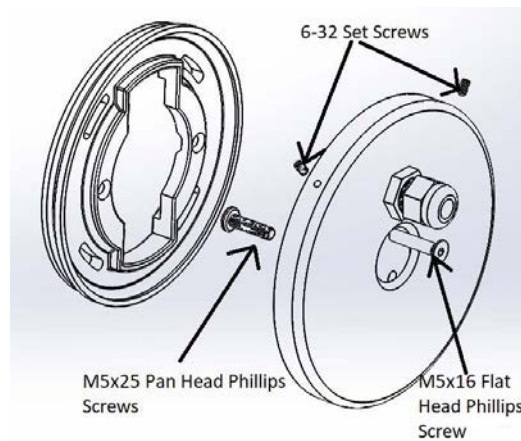

Canopy Assembly Exploded View

PIVOT WITH CANOPY

Accessory Installation- Mounting over J-Box (AC-00003H)

This fixture modification involves cutting and splicing of the original cord.



Fixture cord before modification



Fixture cord after modification



Feed cord through cord grip



Position and screw in circular piece using screws provided and screw fixture in place (See previous page for proper alignment of screws).

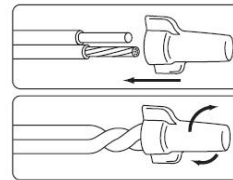

- Use gel-filled waterproof wire-nuts for wire connections.

- Make proper wiring connections. Connect both ends of the wiring, making the proper splicing, and enclose with heat shrink tubing.
- Mount the wall plate to the wall using the support screws (by others).
- Run the end of the wire with the cable gland through the wire hole cutout and reducer plate mounted on the wall.
- Mount the canopy fixture over the wall plate via 2 6-32 set screws using the allen key provided.
- Do this for the two holes on the canopy plate and ensure that the fixture is properly secured to the wall.
- Fixture should be oriented as shown below, with the fixture in between the two set screws.
- It is the contractor's responsibility to caulk around the edges between the fixture and the mounting surface to satisfy wet label requirements.
- It is the contractor's responsibility to install Remote Driver in a suitable electrical enclosure.

