



INSTRUCTIONS PERTAINING TO RISK OF FIRE OR INJURY TO PERSONS. READ ALL INSTRUCTIONS. IMPORTANT SAFETY INSTRUCTIONS. SAVE THESE INSTRUCTIONS.

DANGER - RISK OF SHOCK - DISCONNECT POWER BEFORE INSTALLATION! Please read all instructions before installation.

- Keep these instructions for future reference.
- Must be installed by a qualified electrician in accordance with national and local standards. Designplan is not responsible for fixtures installed without regard to these standards.
- Unauthorized alterations or tampering of product voids warranty.
- The main power connection must be in accordance with local electrical codes.
- Suitable for OUTDOOR applications.



IP66 IK10

ATTENTION: For Wall/Ceiling - It is the contractor's responsibility to caulk around all the edges between the fixture and the mounting surface to satisfy wet label requirements. Contractor **MUST** use gel-filled wire nuts.

Maintenance

Scheduled maintenance must be carried out once a year on all lighting devices, regardless of appliance class and type of use. It must include the following operations:

- Periodically clean fixtures to remove dirt from gratings and screw heads.
- Check tightness of screws on various parts of the device.
- Check that all cable glands and cables are intact and tight. Check that the glass or plastic lens is intact, and replace it if broken or damaged.
- The internal components such as the ballast, driver, washers and screws must not show clear signs of oxidation or rust. Clear traces of rust and oxidation will indicate the presence of water inside the device.
- In the case of damage, the components must be replaced by original components or spare parts.

COD. 101601

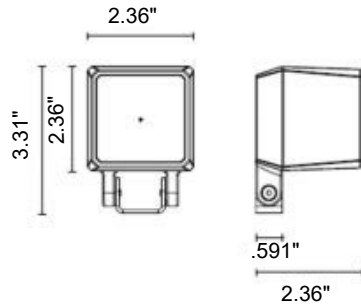

QUBO MICRO HP

- Power consumption : 6W
- Voltage : 220-240V 50-60Hz
- Color Temperature : 3000K - 4000K
- Beam angle : 4°-10°-28°
- Insulation class: III
- IK rating : IK10
- IP protection: IP66
- Gross weight: 0.7kg

COD. 101605

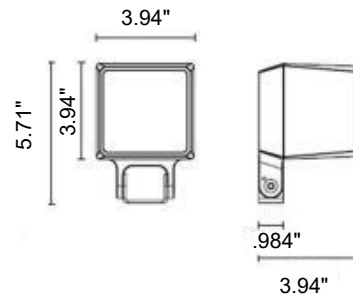

QUBO MINI HP

- Power consumption : 8W
- Voltage : 220-240V 50-60Hz
- Color Temperature : 3000K - 4000K
- Beam angle : 4°-10°-28°
- Insulation class: I
- IK rating : IK10
- IP protection: IP66
- Gross weight: 1.3kg

COD. 101606

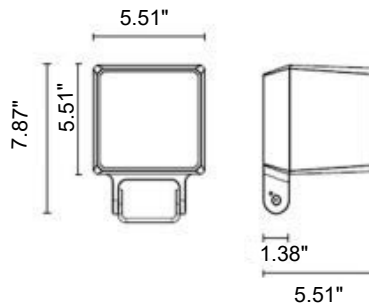

QUBO MEDIUM HP

- Power consumption : 20W
- Voltage : 220-240V 50-60Hz
- Color Temperature : 3000K - 4000K
- Beam angle : 4°-10°-28°
- Insulation class: I
- IK rating : IK10
- IP protection: IP66
- Gross weight: 3.1kg

COD. 101607

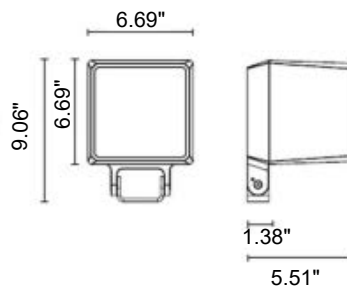

QUBO MAXI HP

- Power consumption : 38W
- Voltage : 220-240V 50-60Hz
- Color Temperature : 3000K - 4000K
- Beam angle : 4°-10°-28°
- Insulation class: I
- IK rating : IK10
- IP protection: IP66
- Gross weight: 4.5kg

Fixture Installation

- Loose the two bracket screws (using the tool included in the package) and remove the fixing bracket (pic.1)
- Measure and mark holes in correspondence to the feeding point (pic. 2)
- Fix the bracket to the floor and tighten the screws of fischer plugs (not included in the package) (pic. 3)
- Prepare the cable through the feeding point hole (pic 4)
- Make the adequate electrical connections
- Fix the luminaire to the bracket and tighten the two hexagonal screws (pic. 5)
- Make the regulation of the luminaire and then fix it by tightening the grub screw (using the tool included in the package) (pic 7)

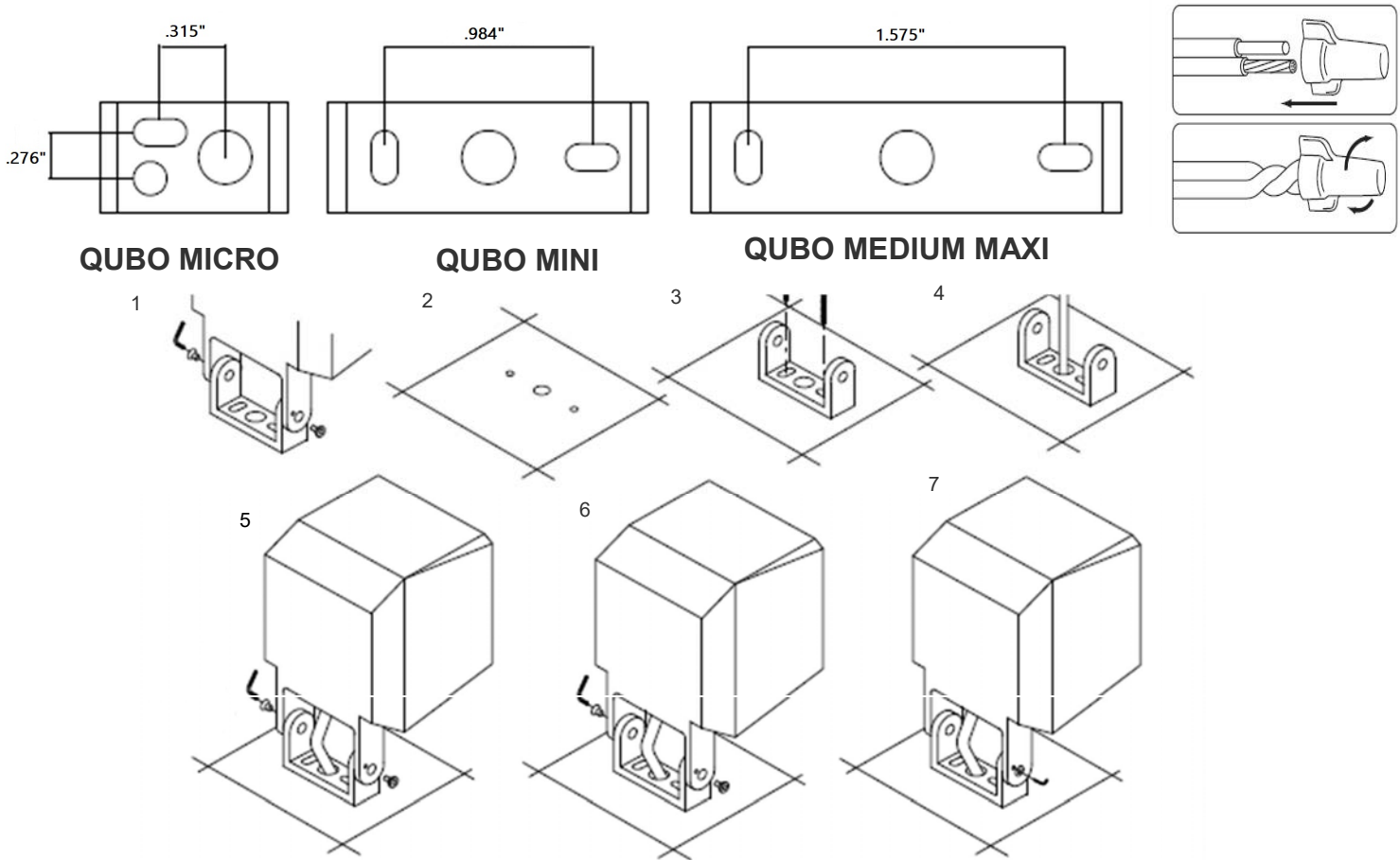

ACCESSORIES

AC044
SPIKE



AC074
HONEYCOMB LOUVER

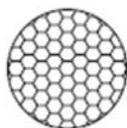

AC078
ANTI-GLARE VISOR



AC038
TREE STRAP

