



INSTRUCTIONS PERTAINING TO RISK OF FIRE OR INJURY TO PERSONS. READ ALL INSTRUCTIONS. IMPORTANT SAFETY INSTRUCTIONS. SAVE THESE INSTRUCTIONS.

DANGER - RISK OF SHOCK - DISCONNECT POWER BEFORE INSTALLATION! Please read all instructions before installation.

- Keep these instructions for future reference.
- Must be installed by a qualified electrician in accordance with national and local standards. Designplan is not responsible for fixtures installed without regard to these standards.
- Unauthorized alterations or tampering of product voids warranty.
- The main power connection must be in accordance with local electrical codes.
- Suitable for OUTDOOR applications.



ATTENTION: For Wall/Ceiling - It is the contractor's responsibility to caulk around all the edges between the fixture and the mounting surface to satisfy wet label requirements. Contractor **MUST** use gel-filled wire nuts.

Maintenance

Scheduled maintenance must be carried out once a year on all lighting devices, regardless of appliance class and type of use. It must include the following operations:

- Periodically clean fixtures to remove dirt from gratings and screw heads.
- Check tightness of screws on various parts of the device.
- Check that all cable glands and cables are intact and tight. Check that the glass or plastic lens is intact, and replace it if broken or damaged.
- The internal components such as the ballast, driver, washers and screws must not show clear signs of oxidation or rust. Clear traces of rust and oxidation will indicate the presence of water inside the device.
- In the case of damage, the components must be replaced by original components or spare parts.

RING MEGA COB

FIXTURE INSTALLATION

installation instructions

- It is the contractor's responsibility to caulk around the edges in between the fixture and the mounting surface, to satisfy wet label requirements.
- Use gel-filled waterproof wire-nuts for wire connections.

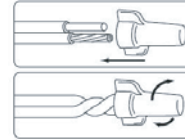

1. Loosen the three grub-screws in the base and remove the cover **pic.1**
2. Prepare holes in correspondence to the feeding point **pic. 2**
3. Insert the cable through the cable gland and fix the base by tightening the screws of the fischer inserts, use two o-rings. Make the adequate electrical connection **pic. 3**
4. Close the luminaire by tightening the three grub-screws, using the tool included in the package **pic.6**
5. Make the regulation of the luminaire horizontal and vertical and then fix it by tightening the grub screws **pic 5-6**

RING MEGA COB

- Power consumption : 82W
- Remote driver
- Beam angle : 20°- 40°
- Insulation class: II
- IK rating : IK10
- IP protection: IP66
- Gross weight: 8kg

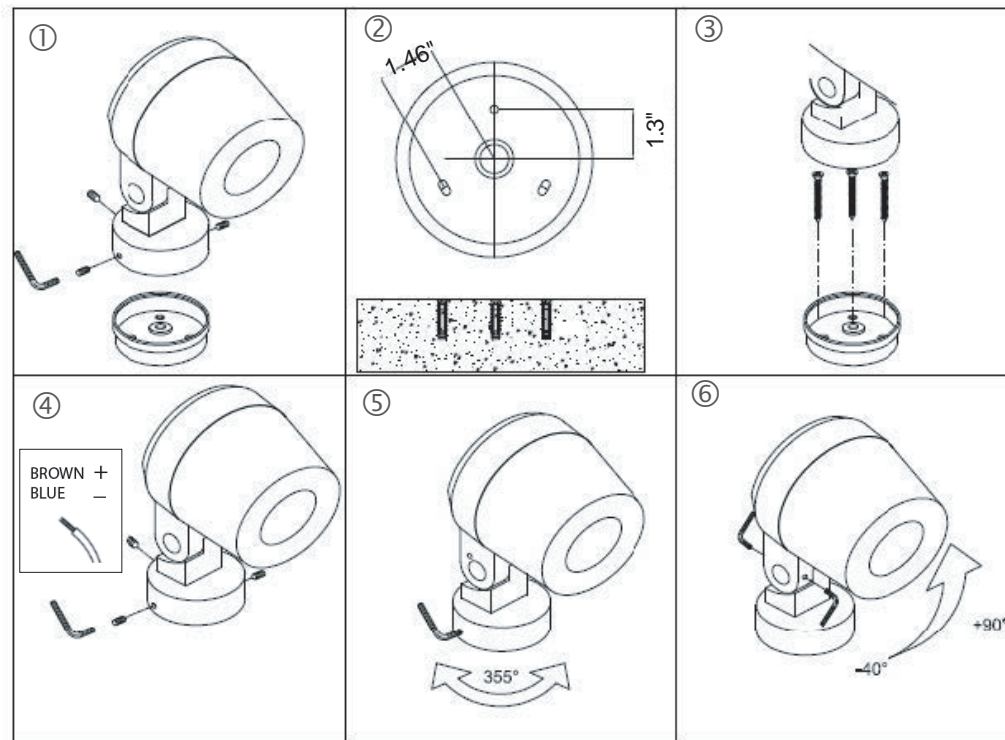
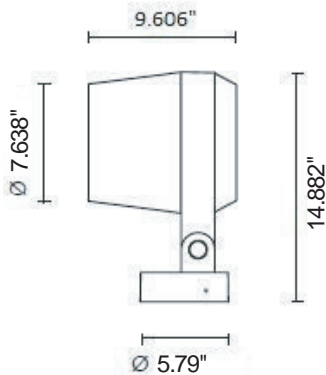

1. Loose the three grub-screws in the base and remove the cover **pic.1**
2. Prepare holes in correspondance of the feeding point **pic. 2**
3. Fix the base by tighten the screws of the fischer plugs,insert the cable through the cable gland making the adequate electrical connection **pic3**
4. Close the luminaire by tighten the three grub-screws using the tool included in the package **pic. 6**
5. Make the regulation of the luminaire horizontal and vertical and then fix it by tighten the grub screws **pic 5-6**

