



**INSTRUCTIONS PERTAINING TO RISK OF FIRE OR INJURY TO PERSONS. READ ALL INSTRUCTIONS. IMPORTANT SAFETY INSTRUCTIONS. SAVE THESE INSTRUCTIONS.**

**DANGER - RISK OF SHOCK - DISCONNECT POWER BEFORE INSTALLATION! Please read all instructions before installation.**

- Keep these instructions for future reference.
- Must be installed by a qualified electrician in accordance with national and local standards. Designplan is not responsible for fixtures installed without regard to these standards.
- Unauthorized alterations or tampering of product voids warranty.
- The main power connection must be in accordance with local electrical codes.
- Suitable for OUTDOOR applications.



**IP65 IK08**

**ATTENTION:** *It is the contractor's responsibility to properly install the fixture base on mounting surface without blocking designated weep holes!*  
**DO NOT CAULK AROUND THE FIXTURE COVER!**

## Maintenance

Scheduled maintenance must be carried out once a year on all lighting devices, regardless of appliance class and type of use. It must include the following operations:

- Periodically clean fixtures to remove dirt from gratings and screw heads.
- Check tightness of screws on various parts of the device.
- Check that all cable glands and cables are intact and tight. Check that the glass or plastic lens is intact, and replace it if broken or damaged.
- The internal components such as the ballast, driver, washers and screws must not show clear signs of oxidation or rust. Clear traces of rust and oxidation will indicate the presence of water inside the device.
- In the case of damage, the components must be replaced by original components or spare parts.

## FIXTURE INSTALLATION

- Prepare holes in correspondence of the feeding point and fix the base using two plugs not included in the package pic. 1
- Loose the grub-screw in the base and remove the cover pic.2
- Make an adequate electrical connection and fix the base pic 3
- Close the luminaire by tighten the grub-screw using the tool included in the package pic. 4
- Cable can also pulled out from the side

### DO NOT CAULK AROUND THE FIXTURE COVER!

Use gel-filled waterproof wire-nuts for wire connections. (IF APPLICABLE)

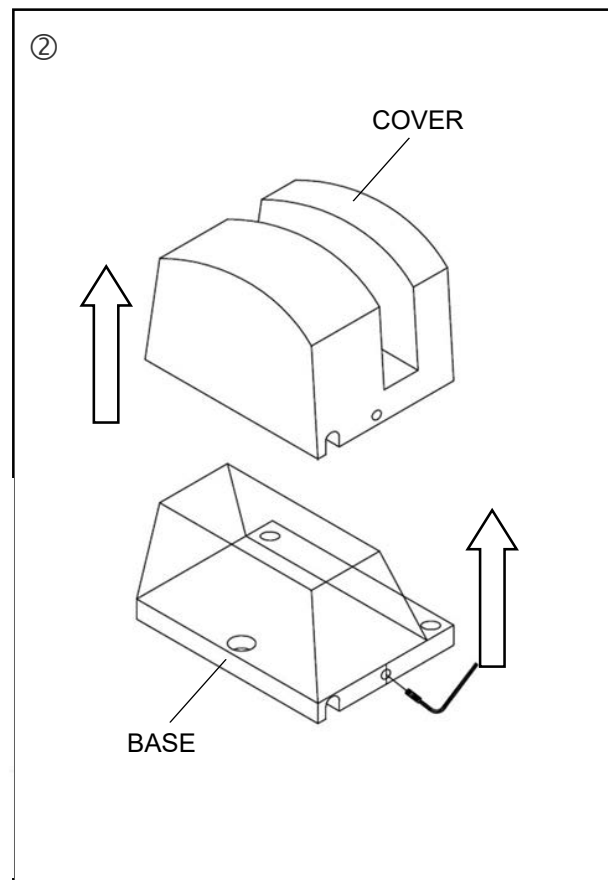
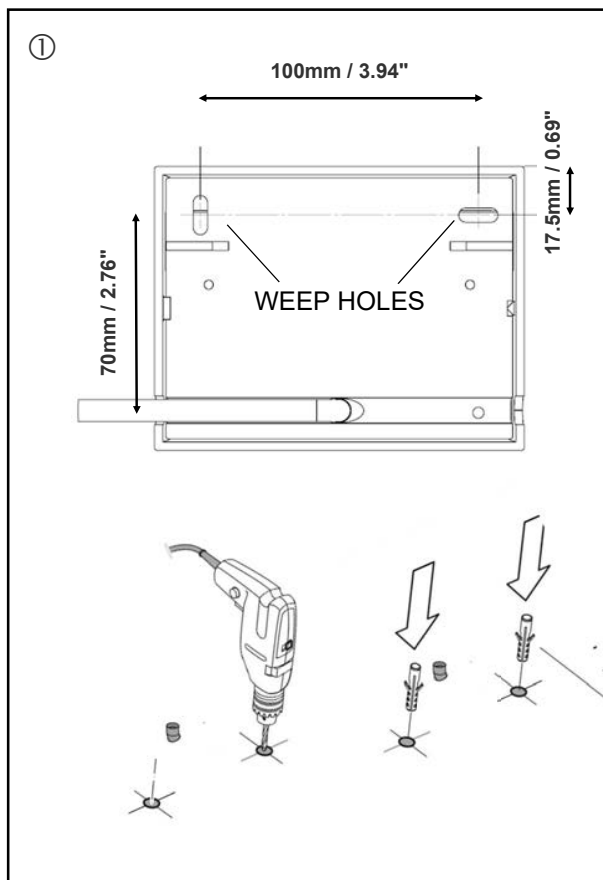
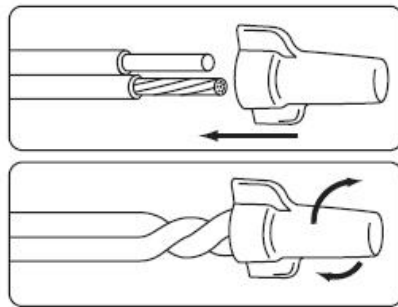

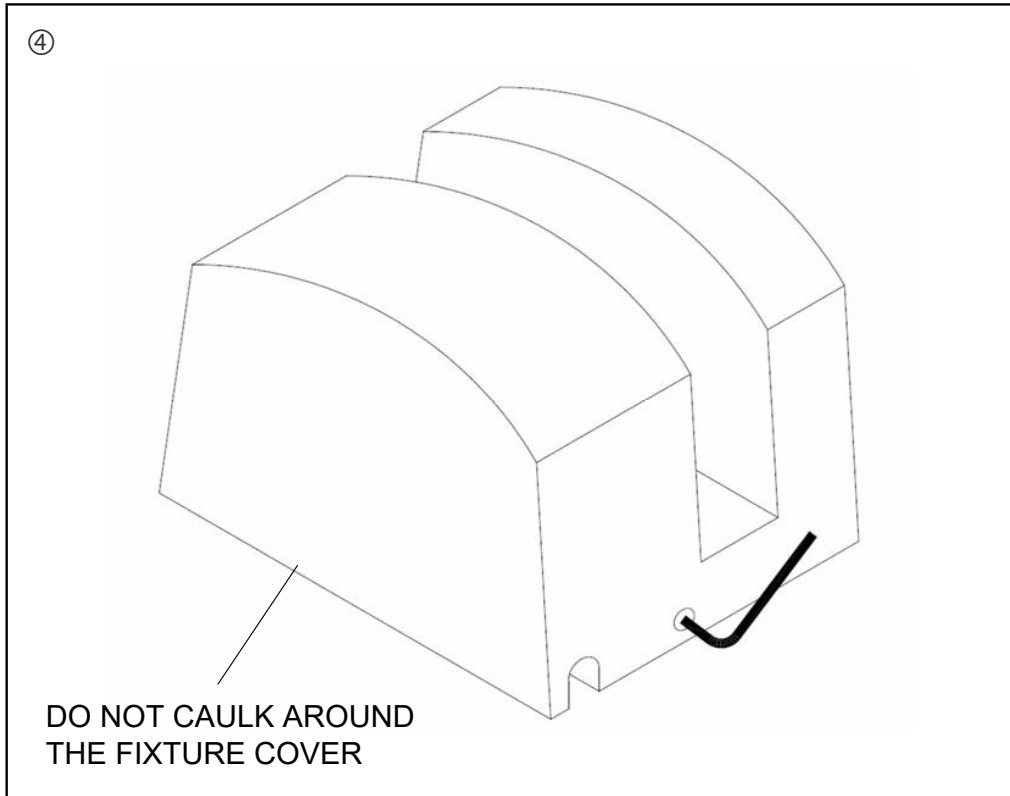
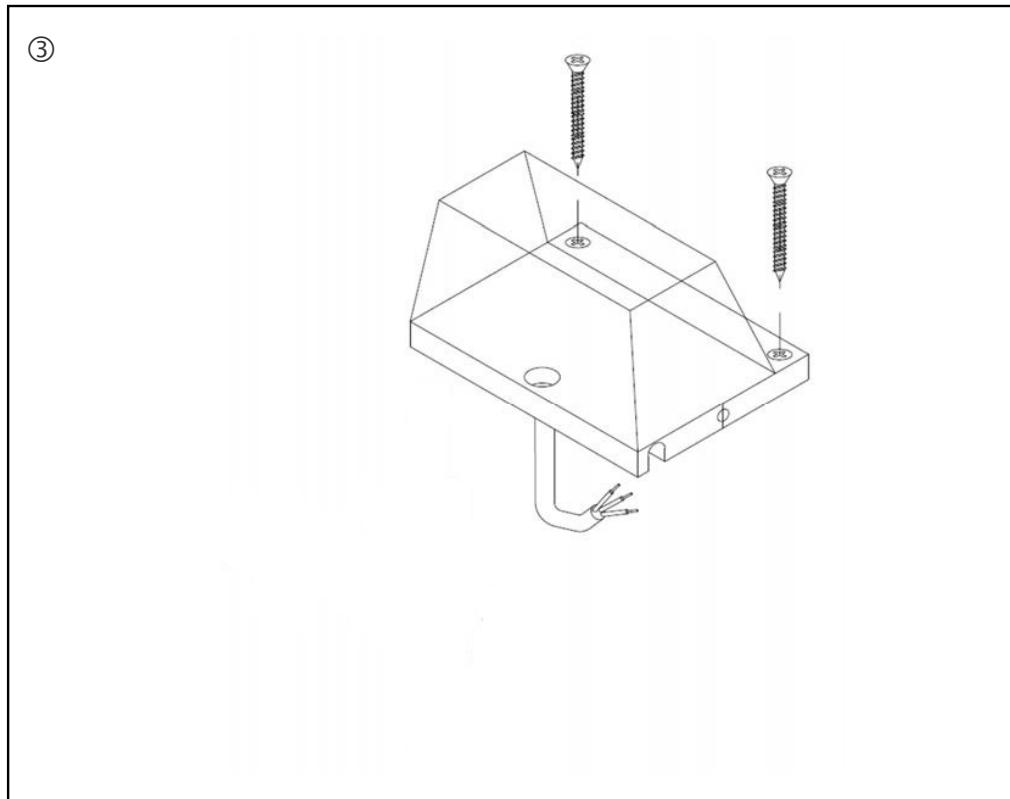

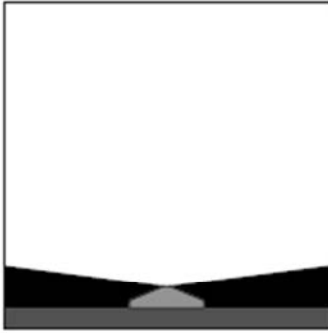

170°

SINGLE INSTALLATION,  
IN THE MIDDLE:  
SUGGESTED FOR  
**SMALL / MEDIUM**  
SIZE WINDOWS

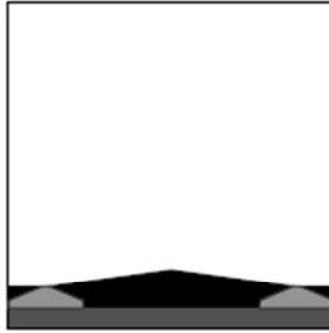

170°

DOUBLE INSTALLATION,  
ON BOTH SIDES:  
SUGGESTED IN CASE  
OF **HIGH LIGHTING**  
**PERFORMANCE**  
NEEDED

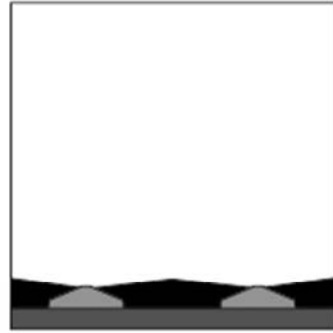

170°

DOUBLE  
INSTALLATION,  
IN THE MIDDLE:  
SUGGESTED FOR  
**BIG SIZE WINDOWS**



SIDE KNOCKOUT  
FOR CABLE