

ZEN



SUSPENSION LAMP WITH SATIN-FINISHED SHADE, VISIBLE OR RECESSED CEILING BOX



Zen

A/C

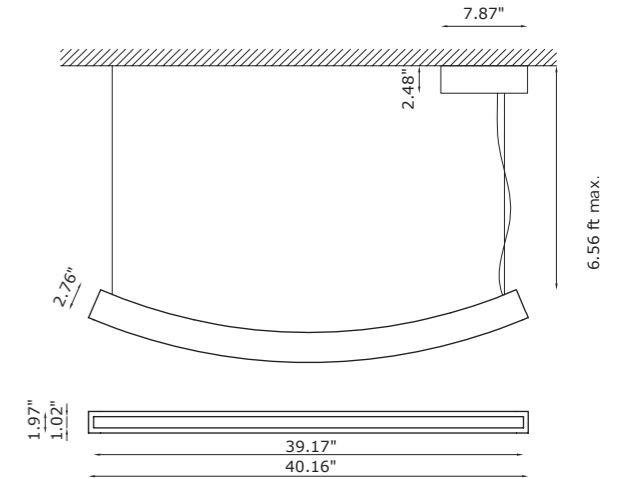

OTHER AVAILABLE CODES

BU1451.27.AC	<i>lens</i>	120°
	<i>light color</i>	2700K

TECHNICAL FEATURES

Code	BU1451.AC
Type	Suspension lamp
Material	AC: AirCoral®
Absorption capacity*	145.74 ft²
Mounting	Ceiling mounting
IP rating	IP40
Control gear	Constant voltage LED driver (included)
Cut out for plasterboard	-
Lamp type	LED 24V
Lamp wattage	1 × 30W
Luminous efficacy	1 × 3150 lm
Light distribution	Wide beam 120°
Fitting	-
Light color	White 3000K
Voltage connection	220-240V · 50/60Hz
CRI	>80
Note	Cable L max 2 m.
	White box ceiling for LED driver.
	Matte polycarbonate screen.
	Other available light colors: 2700K.

designplan® 

79 Trenton Avenue
Frenchtown, NJ 08825

www.designplan.com

Tel: (908) 996-7710
Fax: (908) 996-7042

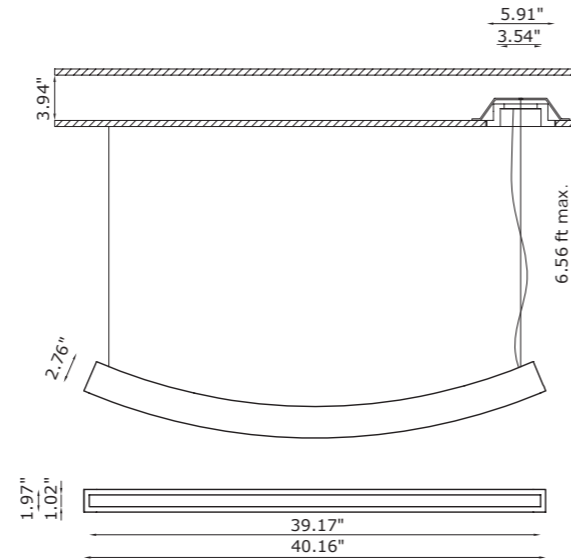

Zen

AC

TECHNICAL FEATURES

Code	BU1452.AC
Type	Suspension lamp
Material	AC: AirCoral®
Absorption capacity*	145.74 ft²
Mounting	Ceiling mounting
IP rating	IP40
Control gear	Constant voltage LED driver (included)
Cut out for plasterboard	Ø 6.30 in
Lamp type	LED 24V
Lamp wattage	1 × 30W
Luminous efficacy	1 × 3150 lm
Light distribution	Wide beam 120°
Fitting	-
Light color	White 3000K
Voltage connection	220-240V · 50/60Hz
CRI	>80
Note	Cable L max 2 m.
	Recessed box of total disappearance for LED driver.
	Matte polycarbonate screen.

designplan® 

79 Trenton Avenue
Frenchtown, NJ 08825

www.designplan.com

Tel: (908) 996-7710
Fax: (908) 996-7042



Private Villa, Austria | ASZ Architetti | ph. SUPERFUTUREDESIGN®

* The absorption capacity per ft² calculated by the American organization TCNA (Tile Council of North America) is measured for an average room of 8.86 ft in height and therefore expressed in ft²