



INSTRUCTIONS PERTAINING TO RISK OF FIRE OR INJURY TO PERSONS. READ ALL INSTRUCTIONS. IMPORTANT SAFETY INSTRUCTIONS. SAVE THESE INSTRUCTIONS.

DANGER - RISK OF SHOCK - DISCONNECT POWER BEFORE INSTALLATION! Please read all instructions before installation.

- Keep these instructions for future reference.
- Must be installed by a qualified electrician in accordance with national and local standards. Designplan is not responsible for fixtures installed without regard to these standards.
- Unauthorized alterations or tampering of product voids warranty.
- The main power connection must be in accordance with local electrical codes.
- Suitable for INDOOR applications.
- DO NOT INSTALL INSULATION WITHIN 3.0" (76 mm) OF ANY PART OF THE LUMINAIRE.



Electrical Connections:

- LED lights must be **connected in series** respecting polarities.
- **CHOOSE POWER SUPPLY ACCORDINGLY.** Please consider the voltage through which fixtures are fed as well as the max power consumption.
- **Connect power only if all fixtures are connected.**
- The power supplies **MUST** be installed in aerated rooms, far from heat sources. Overworking or lack of air circulation will not permit natural dissipation.
- The electronic power supply is current-stable, therefore it partially compensates the voltage-drop problems related to the cable length; we suggest not to exceed 100 ft.
- Use only Class 2 type electronic power supply.
- Never use switches on secondary circuit.

Maintenance

Scheduled maintenance must be carried out once a year on all lighting devices, regardless of appliance class and type of use. It must include the following operations:

- Periodically clean fixtures to remove dirt from gratings and screw heads.
- Check tightness of screws on various parts of the device.
- Check that all cable glands and cables are intact and tight. Check that the glass or plastic lens is intact, and replace it if broken or damaged.
- The internal components such as the ballast, driver, washers and screws must not show clear signs of oxidation or rust. Clear traces of rust and oxidation will indicate the presence of water inside the device.
- In the case of damage, the components must be replaced by original components or spare parts.

Housing Installation

- Fixture comes supplied with a flat sheet metal housing that easily folds into a box shape by bending along the provided slots. Bend the 1/2" tabs down along the sides of the housing box to lock shape into place. Contractor will need to provide two (2) 2x4 wood blocks, (cut long enough to span the top and bottom of the gypsum cutout - see diagram), and six (6) drywall screws of a suitable length, two (3) screws per block.
- Cut out an opening in the gypsum large enough to accept the sheet metal housing box. Place the 2x4 wood blocks inside the top and bottom of the opening and secure with drywall screws. The face of the 2x4 wood blocks must be flush with cutout surface of the gypsum. These wood blocks will provide support for the sheet metal housing box. The housing box has several "U" shaped tabs on all four sides that must be bent towards the inside of the housing box. Bend tabs to about a 30 degree angle. These tabs will hold the calcyt fixture securely in place when fixture is mounted. There are 7/8" diameter holes provided in the backside of the sheet metal fixture housing for passing building powerline thru. It is the contractors responsibility to provide suitable conduit fittings to suit job wiring conditions. Pass power cable thru conduit fitting. Secure housing box to 2x4 wood blocks. It is the contractor's responsibility to supply proper mounting based on job condition. After housing box has been mounted, snap off the four (4) locating tabs. Housing box installation is now complete.

Housing Installation

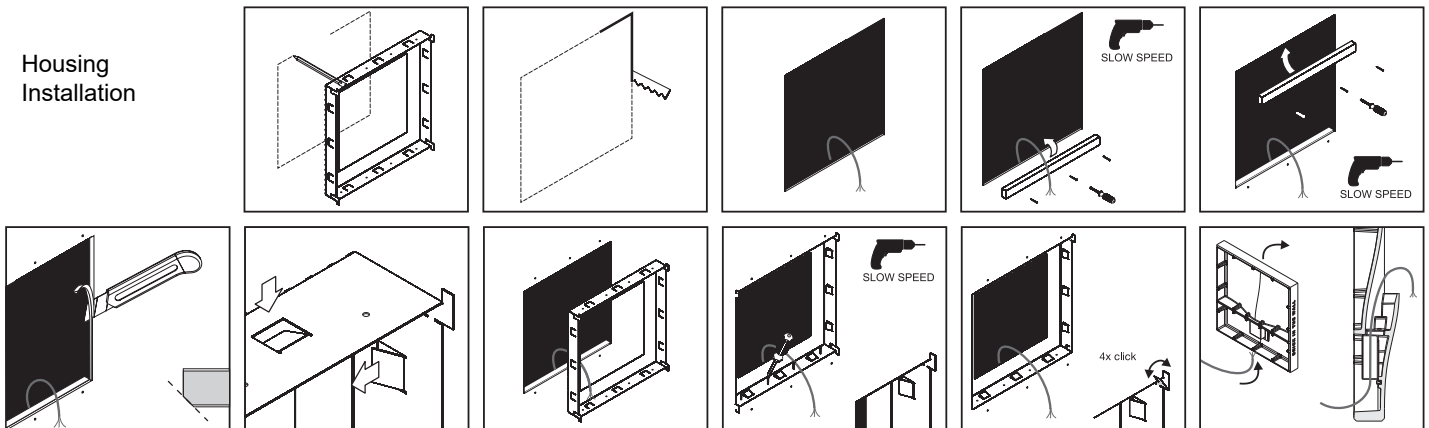

Fixture Installation

- Feed the supply lead thru the hole in the back of the calcyt fixture. Insert the calcyt fixture into the housing box opening. It is recommended to use a level to gently push the calcyt into the housing box. This will ensure that the front surface of the calcyt remains flush with the surrounding gypsum surface. The “U” shaped tabs in the housing box will grip the calcyt fixture body, holding it in place.
- Use joint compound and fiberglass tape to seal up all seams all around the fixture in preparation of final plastering. When dry, apply thin coating of plaster to blend in the calcyt fixture to the surrounding gypsum. If painting the plaster for the first time, dilute the paint about 15%. For the second coat, we recommend to dilute the paint about 5%.

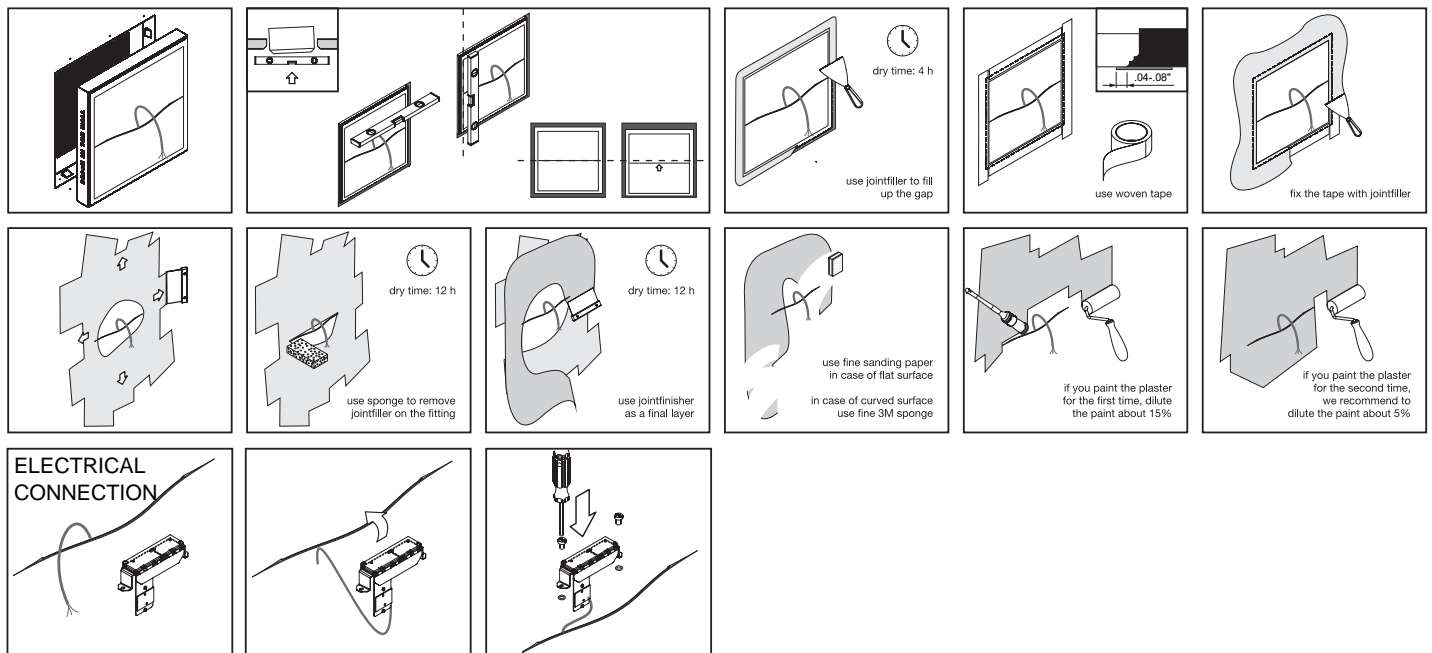

- It is the contractor's responsibility to install Remote Driver in a suitable electrical enclosure.

Wiring Diagram

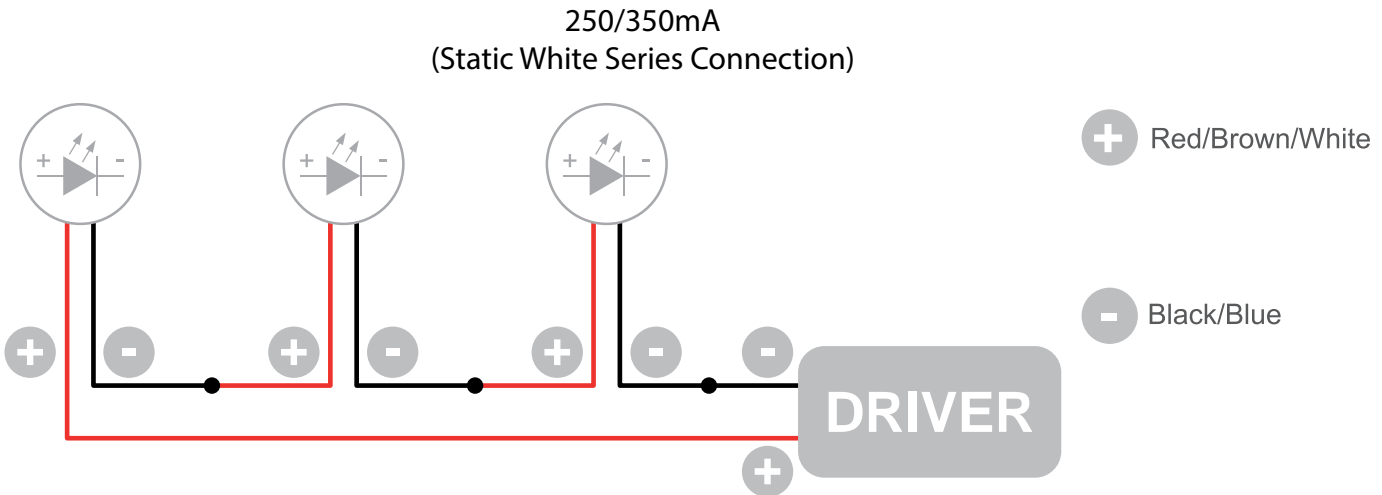

 The individual lamps must be connected in series.
Only power up the system once all the lamps have been connected.

- LED lights work at constant current. When choosing a power supply unit, you need to consider the current! by which the LEDs are driven and their maximum power consumption.
- Only power up the system once all the lamps are connected. Connecting an individual lamp to an active power supply may cause the lamp to break due to over-voltage.
- The electronic power supply is constant current, so to a certain extent it automatically compensates the! voltage drop associated with cable length; however, we advise not exceeding 100 feet.
- Lamps and power supply units must be installed in well-ventilated boxes or locations to allow a natural heat diffusion and avoid the devices overheating.
- On the power system, install a surge protection device to reduce the intensity of any voltage spikes to protect the lighting fixtures from the risk of damage.
- Fixture NOT suitable for covering with thermally insulating material.