

Nefi is a totally disappearing recessed downlight made of AirCoral® that is suitable for indoor installation on plasterboard or brick ceilings. It is available in 3000K as standard with a satin glass, creating a harmonious diffusion of light.



TECHNICAL DATA

Wattage / Input	10W (500mA)
Power Supply	Remote, not included. See page 2.
Construction	Body: AirCoral® Lens: Satin Glass
CCT	3000K (2700K, 4000K on request)
CRI	>90
Delivered Lumens	557 lm (3000K)
Efficacy	55.7 lm/W
Optics	40°
Finishes	AirCoral® Paintable Plaster
Fixture Dimensions	5.71" l x 5.71" w x 5.51" h
Aperature Dimension	3.54" x 3.54"
Cut-out Dimension	6.10" x 6.10"
Fixture Weight	3.53 lbs
IP Rating	IP40

Fixture Dimensions

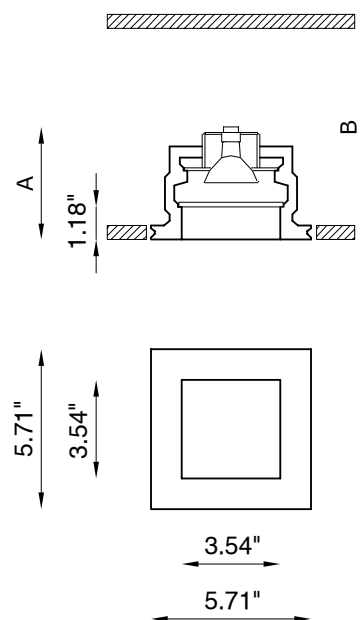

The body is made of Aircoral® a unique patented composite material that actually purifies the air. It can be calculated how many cubic feet each fixture will purify. See website for Aircoral® calculator.

- Additionally, Aircoral® is:
- Antibacterial.
 - Antifungal.
 - Scratch-resistant.
 - Dust-resistant.
 - Suitable for painting.
 - LEED recognized material.

ORDERING INFORMATION

Example: BU6218.Z.AC.US. Power Supplies ordered separately.

BU6218.Z	AC	US
Model No.	Finish	
BU6218.Z	AC - AirCoral®	US

Job Name/Date:

Fixture Type Designation:

SUGGESTED POWER SUPPLIES

500mA

Part Number	Description	Input/Output	# of Fixtures
PPLT00466-P	0-10V Dimming to 1.0%	120-277VAC to 500mA, 10W, Class 2	1-1
PPLT00469	Phase Dim (120V Only)	120VAC to 500mA, 14W, Class 2	1-1
PPLT00308-P	0-10V Dimming to 0.1%	120-277VAC to 500mA, 30W, Class 2	1-2
PPLT00309-P	0-10V Dimming to 0.1%	120-277VAC to 500mA, 50W, Class 2	1-2
PPLT00538-P	0-10V Dimming to 0.1%	120-277VAC to 500mA, 100W, Class 2	1-8

Suggested Lutron Compatible

Part Number	Option	Lutron SKU	Dim Range	Description	Input/Output	# of Fixtures
PPLT00249	LTEA2W	LTEA	100%-1%	Hi-Lume™ 1% 2-Wire LED Driver (120V forward phase only)	120VAC to 500mA, 10W, Class 2	1-1
PPLT00259	L3DAE / L3DA3W	L3DA	100%-1%	Hi-Lume™ 1% EcoSystem™ or 1% 3-Wire LED Driver	120VAC to 500mA, 10W, Class 2	1-1
PPLT00195	L3DAE / L3DA3W	L3DA	100%-1%	Hi-Lume™ 1% EcoSystem™ or 1% 3-Wire LED Driver	120-277VAC to 500mA, 19W, Class 2	1-1
PPLT00180	L3DAE / L3DA3W	L3DA	100%-1%	Hi-Lume™ 1% EcoSystem™ or 1% 3-Wire LED Driver	120-277VAC to 500mA, 27W, Class 2	2-2
PPLT00250	LTEA2W	LTEA	100%-1%	Hi-Lume™ 1% 2-Wire LED Driver (120V forward phase only)	120VAC to 500mA, 27W, Class 2	2-2

For other power supply options consult factory.

PHOTOMETRIC DATA

3000K

Maximum Candela = 685

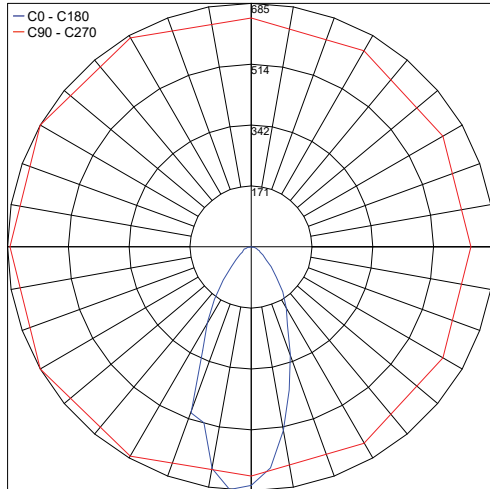

PHOTOMETRIC FILENAME : NEFI BU6218.Z.AC.IES

Job Name/Date:

Fixture Type Designation: