

The Qubo Mini HP is a square, outdoor LED floodlight suitable for installation on a façade/wall with a U-shaped fixing bracket allowing vertical adjustment of +90° / -40°. It has 3 standard finishes and 3 optics options.



TECHNICAL DATA

Wattage / Input	8W (120VAC)
Power Supply	Integral 0-10V Dimming
Construction	Body: Die-Cast Copper-Free Aluminum Screws: Stainless Steel Lens: Tempered, Safety Glass Cable Length: 3.28" included
CCT	3000K, 4000K
CRI	>80
Lumen Output	662 lm (3000K, 10°)
Efficacy	82.8 lm/W (3000K, 10°)
Optics	3 Standard (see below)
Finishes	3 Standard, Custom RAL (see below)
Fixture Dimensions	3.94" l x 3.94" w x 5.71" h
Fixture Weight	2.87 lbs
LED Source	1 x CREE "XHP35" LED
IP Rating	IP66
Impact Rating	IK10

Fixture Dimensions

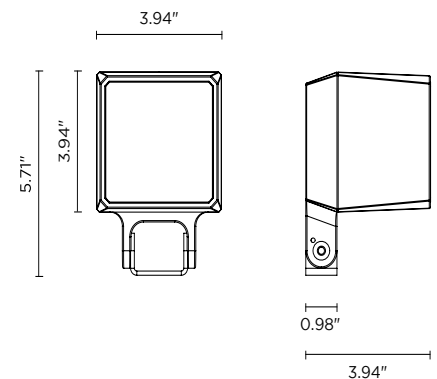

ORDERING INFORMATION

Example: 101605P-30K-10-TG. Accessories ordered separately.

101605P	-		-		-	
Model No.	CCT	Optics	Finish			
101605P	30K - 3000K 40K - 4000K	04 - 4° 10 - 10° 28 - 28°	TG - Textured Grey (RAL 9006) AG - Anthracite Grey (RAL 7016) MB - Matte Black (on request)			

Job Name/Date:

Fixture Type Designation:

ACCESSORIES

Installation



AC044
Ground Spike

Anti-Glare

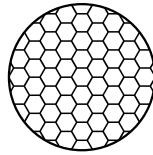

AC072
Honeycomb Louver



AC076
Anti-Glare Visor



AC038
Tree Strap
for Ring Series

PHOTOMETRIC DATA

Note: All photometry is 3000K

Maximum Candela = 10144.1

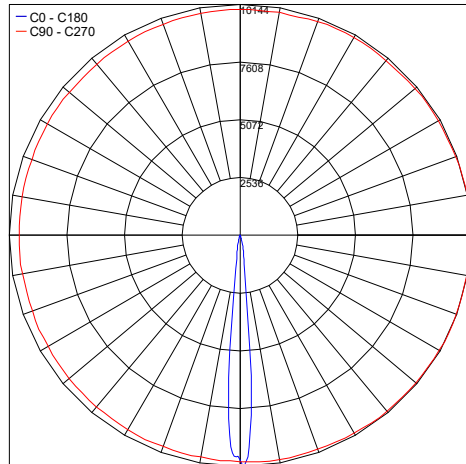

PHOTOMETRIC FILENAME : QUBO MINI HP 3000K 4' 8W 101605PIES

Maximum Candela = 5315.7

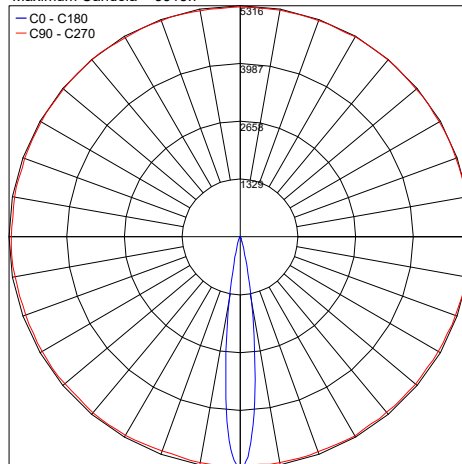

PHOTOMETRIC FILENAME : QUBO MINI HP 3000K 10' 8W 101605PIES

Maximum Candela = 2120.5

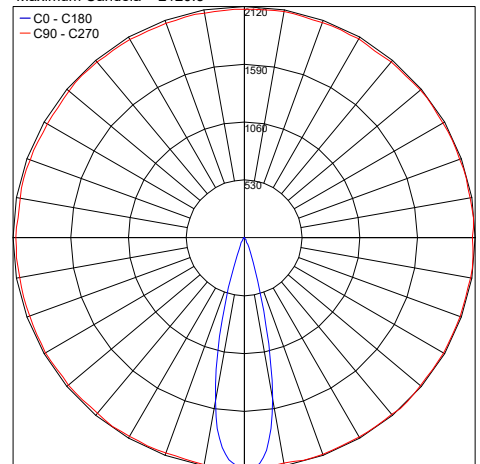

PHOTOMETRIC FILENAME : QUBO MINI HP 3000K 28' 8W 101605PIES

Job Name/Date:

Fixture Type Designation: