



**INSTRUCTIONS PERTAINING TO RISK OF FIRE OR INJURY TO PERSONS. READ ALL INSTRUCTIONS. IMPORTANT SAFETY INSTRUCTIONS. SAVE THESE INSTRUCTIONS.**

**DANGER - RISK OF SHOCK - DISCONNECT POWER BEFORE INSTALLATION! Please read all instructions before installation.**

- Keep these instructions for future reference.
- Must be installed by a qualified electrician in accordance with national and local standards. Designplan is not responsible for fixtures installed without regard to these standards.
- The main power connection must be in accordance with local electrical codes.
- Unauthorized alterations or tampering of product voids warranty.
- Suitable for OUTDOOR applications.



## Electrical Connections:

- LED lights must be **connected in series** respecting polarities.
- **CHOOSE POWER SUPPLY ACCORDINGLY.** Please consider the voltage through which fixtures are fed as well as the max power consumption.
- **Connect power only if all fixtures are connected.**
- The power supplies **MUST** be installed in aerated rooms, far from heat sources. Overworking or lack of air circulation will not permit natural dissipation.
- The electronic power supply is current-stable, therefore it partially compensates the voltage-drop problems related to the cable length; we suggest not to exceed 100 ft.
- Use only Class 2 type electronic power supply.
- Never use switches on secondary circuit.

**ATTENTION:** For Wall/Ceiling - It is the contractor's responsibility to caulk around all the edges between the fixture and the mounting surface to satisfy wet label requirements.

For In-Grade - It is the contractor's responsibility to seal the conduit with "Great Stuff" aerosol seal that prevents water and moisture penetration for ultimate protection. Contractor **MUST** use gel-filled wire nuts.

## Maintenance

Scheduled maintenance must be carried out once a year on all lighting devices, regardless of appliance class and type of use. It must include the following operations:

- Periodically clean fixtures to remove dirt from gratings and screw heads.
- Check tightness of screws on various parts of the device.
- Check that all cable glands and cables are intact and tight. Check that the glass or plastic lens is intact, and replace it if broken or damaged.
- The internal components such as the ballast, driver, washers and screws must not show clear signs of oxidation or rust. Clear traces of rust and oxidation will indicate the presence of water inside the device.
- In the case of damage, the components must be replaced by original components or spare parts.

## HOUSING DIMENSIONS



WC4010



WC4011

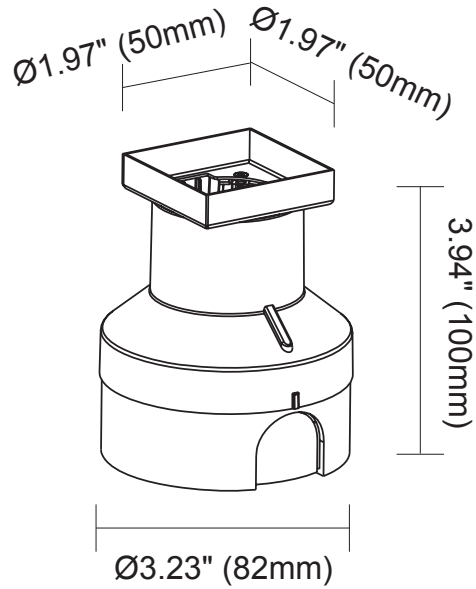
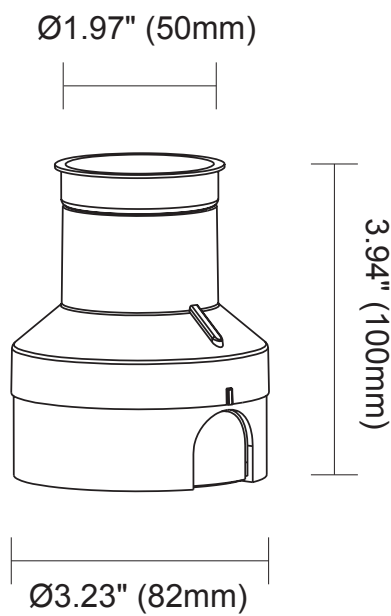

## HOUSING INSTALLATION

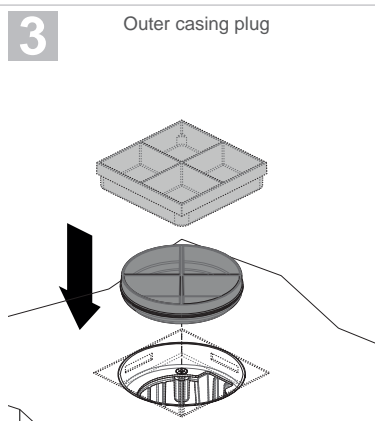
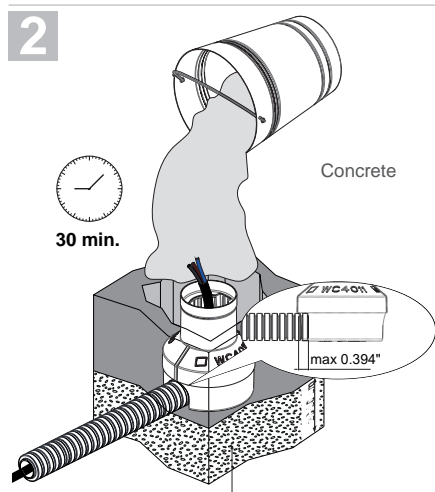
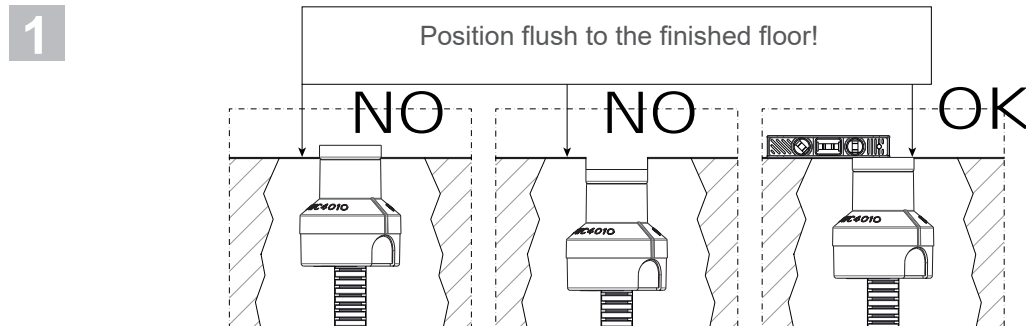

Use 7-12" of drainage gravel - check functionality: fill tube with water and verify full drainage within 30 min. If water remains, please utilize a different drainage system that functions properly. Contractor to seal the conduit with "Great Stuff" aerosol seal that prevents water and moisture penetration for ultimate protection.

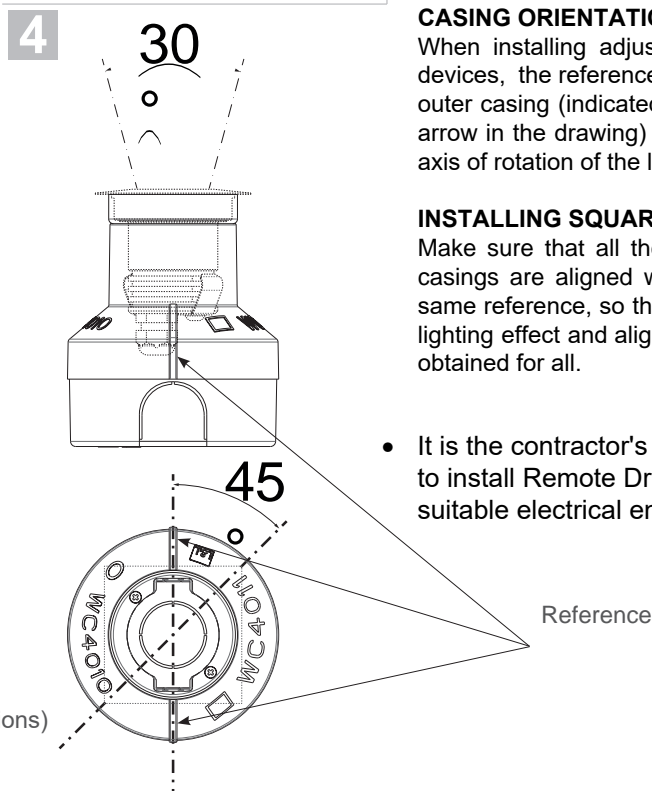
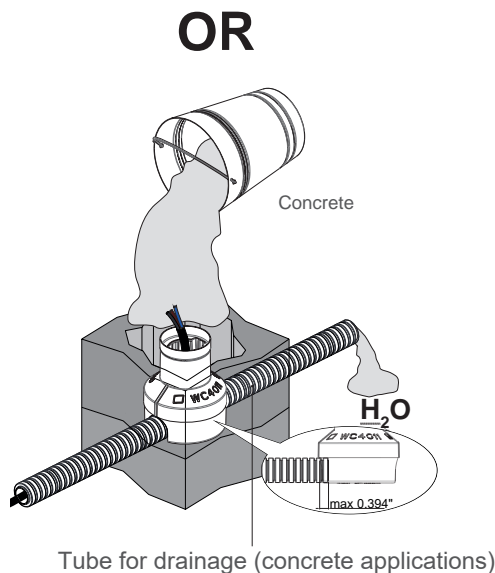

### CASING ORIENTATION

When installing adjustable devices, the reference on the outer casing (indicated by the arrow in the drawing) shows the axis of rotation of the light beam.

### INSTALLING SQUARE CASINGS

Make sure that all the outer casings are aligned with the same reference, so that the same lighting effect and alignment are obtained for all.

- It is the contractor's responsibility to install Remote Driver in a suitable electrical enclosure.

## Fixture Installation

### 1 Package Contents

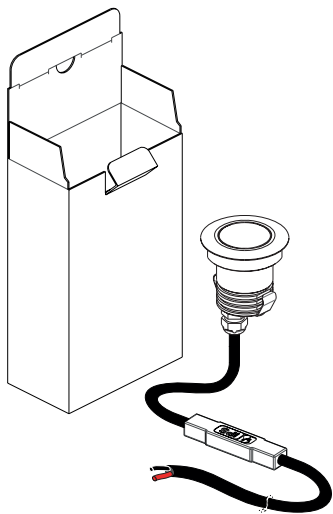

### 2

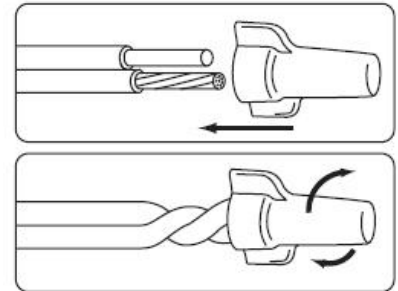
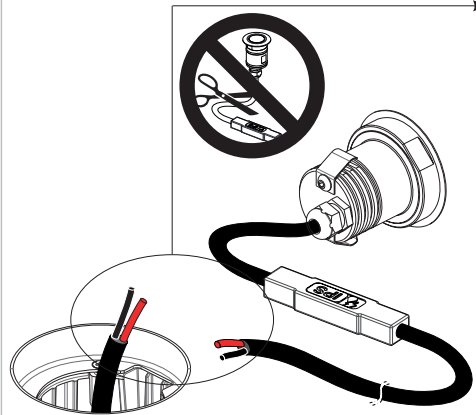

- Use gel-filled waterproof wire-nuts for wire connections.
- It is the contractor's responsibility to install Remote Driver in a suitable electrical enclosure.

### 3

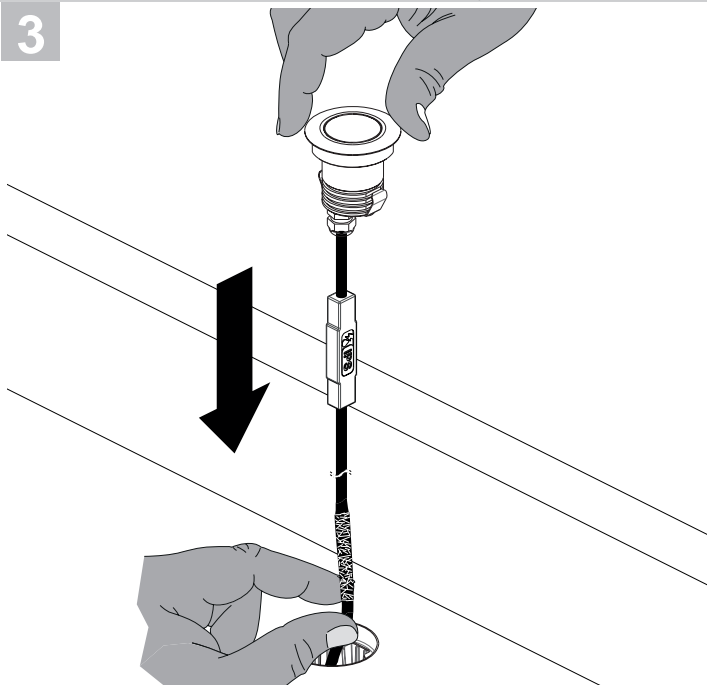

### 4 (WC4010)

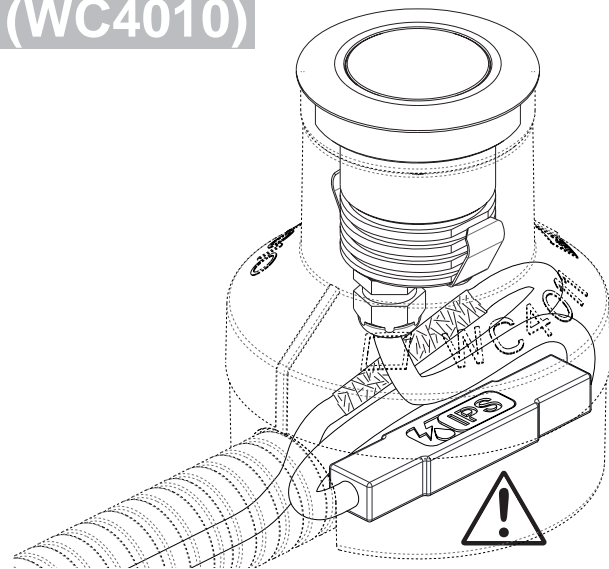

Use conduit  $\text{Ø}20$  mm (0.79") minimum  
(recommended  $\text{Ø}25$  mm (0.98"))

**WG0501:** Spring for recessed mounting  
Smoothy 1.0

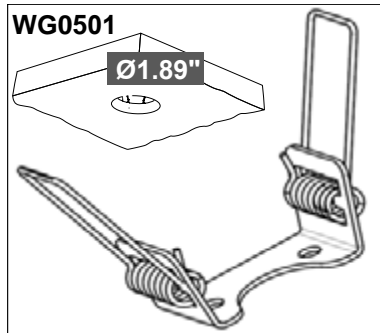

B (in)	X (in)	S (in)	H (min)
Ø1.89	2.3 min	0 ≥ 0.98	4.33

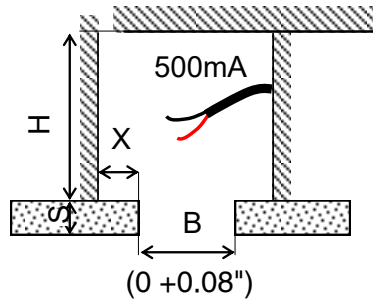

Overall volume  
Ø7.08" x 4.33"

