



FOCAL

D50

H20
H40
H80

D70

H20
H40
H80

designplan® 

79 Trenton Avenue
Frenchtown, NJ 08825

www.designplan.com

Tel: (908) 996-7710
Fax: (908) 996-7042

← FOCAL D70, INOX GRAPHITE, GU10

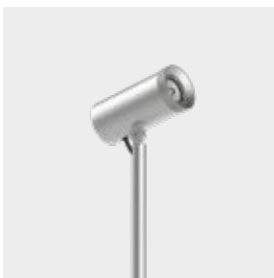





↑ FOCAL D70, INOX GRAPHITE
← FOCAL D70, INOX GRAPHITE, 3000K



Spike for driving into the ground

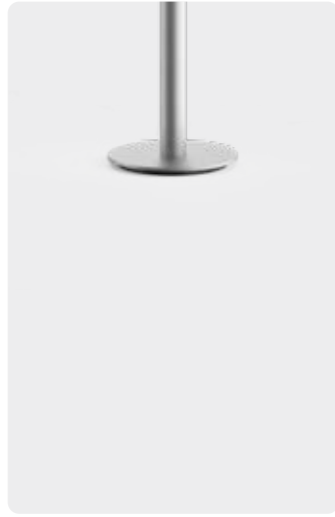

New
Aesthetic flange



New
Casing flange

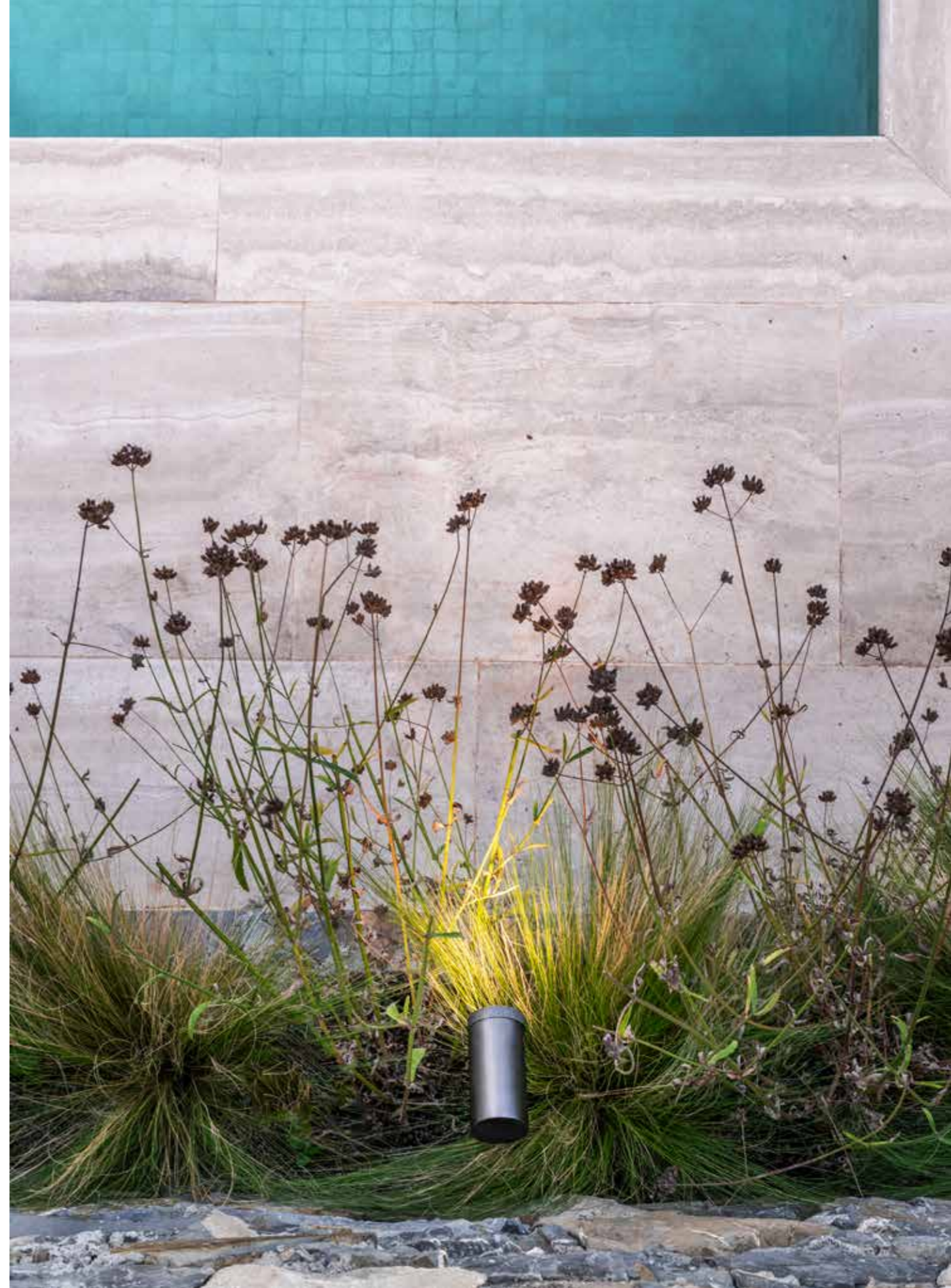



Interchangeable lens kit with various focal lenses included



LED version with interchangeable lenses

Detail of stainless-steel spring for cable protection



Head swiveling

Stainless Steel AISI 316L projector. Available for installation with a ground spike or on an embedded formwork; alternatively, with a baseplate for floor installation in stainless steel AISI 316L. Extra-clear tempered glass, 0.16 inches thick. Power cable protected against cuts and accidental damage. Axial rotation of the head by 180°. LED version supplied with a default 6° optic and a set of interchangeable optics: 15°, 25°, 38°, 10×35°, and wide. Spike accessory for direct ground installation. Formwork accessory for in-ground or concrete installation, which can be equipped with a bottom cap and plaster guard cap. Version with baseplate for installation using anchors. Available IP66 multi-socket plug-in box in thermoplastic material for up to 4 devices. Surface finish HCT available in three variants.

D50

D50 FL

D70

D70 FL



D50

Emission	6° / 15° / 25° / 38° / 10° × 35° / Wide	6° / 15° / 25° / 38° / 10° × 35° / Wide	6° / 15° / 25° / 38° / 10° × 35° / Wide
----------	---	---	---

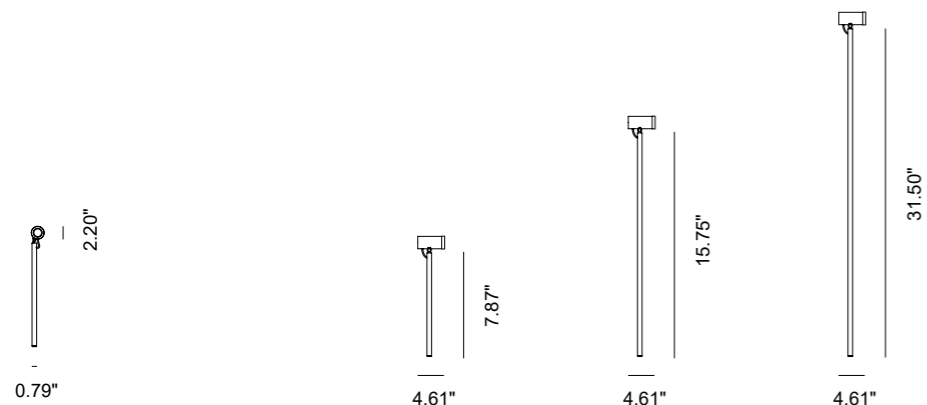

Info	Temperature	2700K (543 lm) / 3000K (550 lm) / 4000K (613 lm)
	Power	LED 5W or GU4 12V (not included)
	Finish	● INOX Natural ● INOX Graphite ● INOX Bronze
	Characteristics	IK08, IP66, DALI
	Accessories	F1, C20, T10, T2, A1, B1, P2

D50 FL

Emission	6° / 15° / 25° / 38° / 10° × 35° / Wide	6° / 15° / 25° / 38° / 10° × 35° / Wide	6° / 15° / 25° / 38° / 10° × 35° / Wide
----------	---	---	---

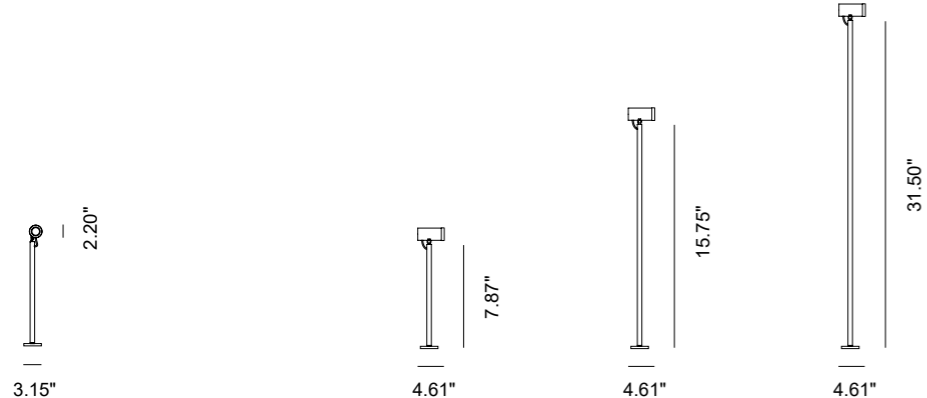

Info	Temperature	2700K (543 lm) / 3000K (550 lm) / 4000K (613 lm)
	Power	LED 5W or GU4 12V (not included)
	Finish	● INOX Natural ● INOX Graphite ● INOX Bronze
	Characteristics	IK08, IP66, DALI
	Accessories	A1, B1

Accessories F1 C20 T10 T2 A1 B1 P2



D70

Emission	6° / 15° / 25° / 38° / 10° × 35° / Wide	6° / 15° / 25° / 38° / 10° × 35° / Wide	6° / 15° / 25° / 38° / 10° × 35° / Wide
----------	---	---	---

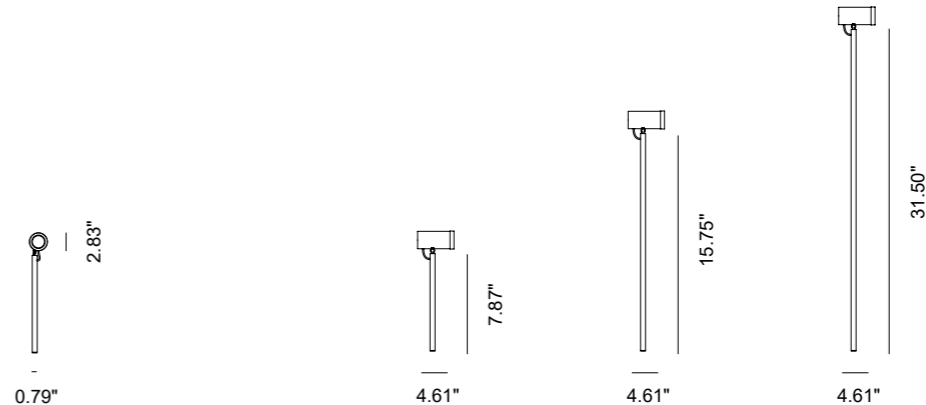

Info	Temperature	2700K (740 lm) / 3000K (750 lm) / 4000K (836 lm)
	Power	LED 7W or GU10 220V (not included)
	Finish	● INOX Natural ● INOX Graphite ● INOX Bronze
	Characteristics	IK08, IP66, DALI
	Accessories	F8, C20, T10, T2, P1

D70 FL

Emission	6° / 15° / 25° / 38° / 10° × 35° / Wide	6° / 15° / 25° / 38° / 10° × 35° / Wide	6° / 15° / 25° / 38° / 10° × 35° / Wide
----------	---	---	---

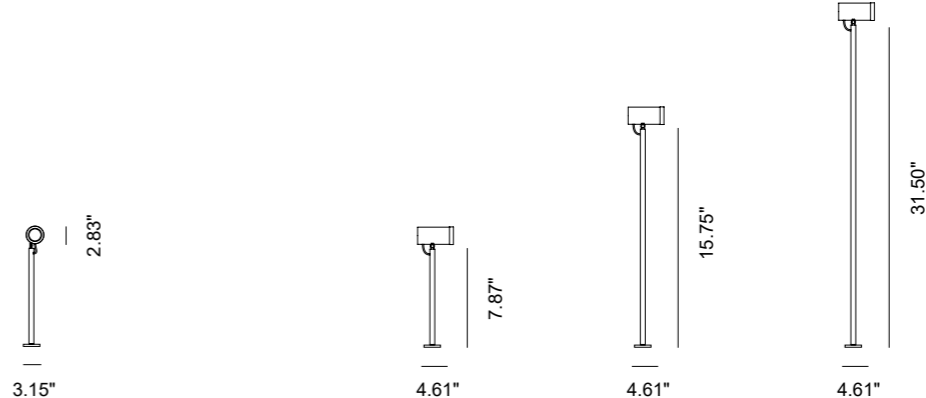

Info	Temperature	2700K (740 lm) / 3000K (750 lm) / 4000K (836 lm)
	Power	LED 7W or GU10 220V (not included)
	Finish	● INOX Natural ● INOX Graphite ● INOX Bronze
	Characteristics	IK08, IP66, DALI
	Accessories	-

Accessories F8 C20 T10 T2 P1

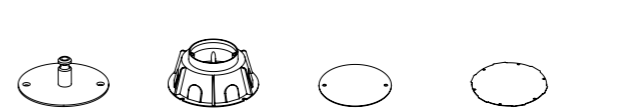



is the USA STRAL's official dealer

79 Trenton Avenue
Frenchtown, NJ

www.designplan.com

Tel: (908) 996-7710
Fax: (908) 996-7042