



INSTRUCTIONS PERTAINING TO RISK OF FIRE OR INJURY TO PERSONS. READ ALL INSTRUCTIONS. IMPORTANT SAFETY INSTRUCTIONS. SAVE THESE INSTRUCTIONS.

DANGER - RISK OF SHOCK - DISCONNECT POWER BEFORE INSTALLATION! Please read all instructions before installation.

- Keep these instructions for future reference.
- Must be installed by a qualified electrician in accordance with national and local standards. Designplan is not responsible for fixtures installed without regard to these standards.
- Unauthorized alterations or tampering of product voids warranty.
- The main power connection must be in accordance with local electrical codes.
- Suitable for INDOOR applications.
- DO NOT INSTALL INSULATION WITHIN 3.0" (76 mm) OF ANY PART OF THE LUMINAIRE.



ATTENTION: For Surface - It is the contractor's responsibility to caulk around all the edges between the fixture and the mounting surface to satisfy wet label requirements.

Maintenance

Scheduled maintenance must be carried out once a year on all lighting devices, regardless of appliance class and type of use. It must include the following operations:

- Periodically clean fixtures to remove dirt from gratings and screw heads.
- Check tightness of screws on various parts of the device.
- Check that all cable glands and cables are intact and tight. Check that the glass or plastic lens is intact, and replace it if broken or damaged.
- The internal components such as the ballast, driver, washers and screws must not show clear signs of oxidation or rust. Clear traces of rust and oxidation will indicate the presence of water inside the device.
- In the case of damage, the components must be replaced by original components or spare parts.

FIXED M01, M02, M03

5W, 10W, 15W Remote 350mA

INSTALLATION AND WIRING

APPLIANCE INSTALLATION PREPARATION :

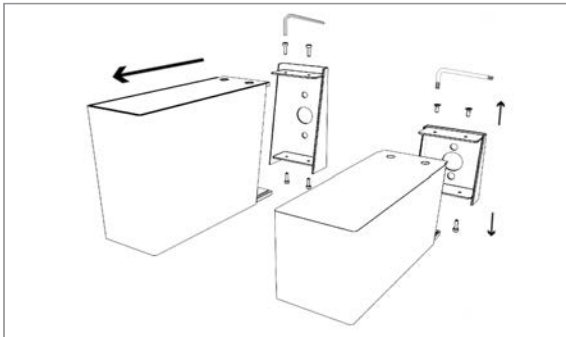

Disassemble device body using T9 Torx key for upper screws and 2.5 mm Allen key for lower screws
For bi-directional version, use the Allen key for both screws

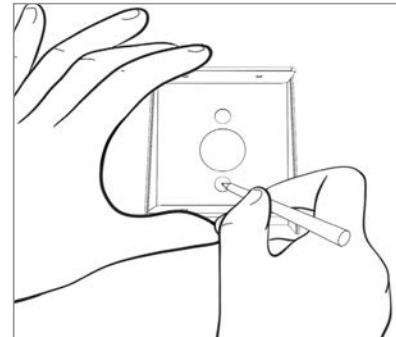

Draw fixing holes

DEVICE BRACKET INSTALLATION AND WIRING :

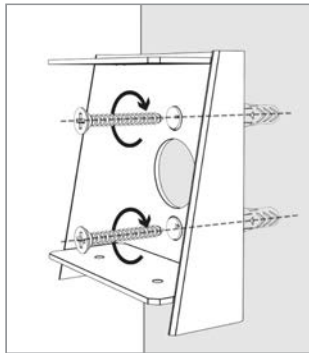

Drill the wall in the traced marks, insert the fixing plugs and align the bracket and screws

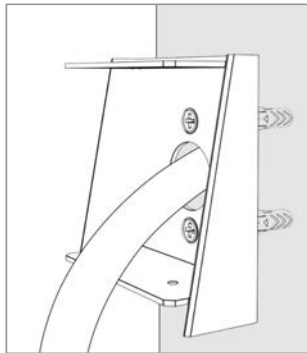

Fix the bracket by guiding the cable through the cable slot

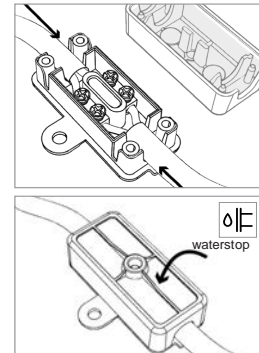

Cable wiring using waterstop connector Suggested cable cross-section - up to 2 x 18 AWG. Cable External diameter min. - max. 0.189" - 0.236" DIA.

DEVICE FIXING AND POSITIONING :

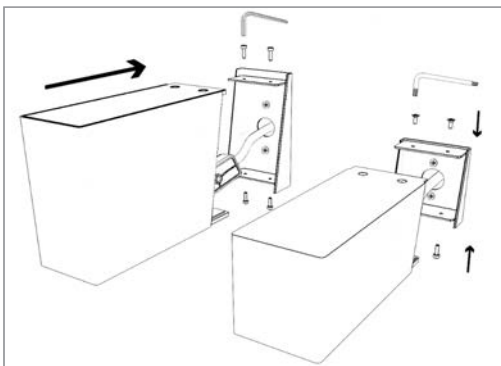

Reassemble device body

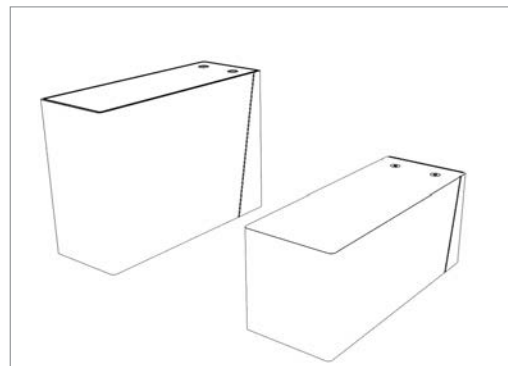

Correctly installed devices

