



INSTRUCTIONS PERTAINING TO RISK OF FIRE OR INJURY TO PERSONS. READ ALL INSTRUCTIONS. IMPORTANT SAFETY INSTRUCTIONS. SAVE THESE INSTRUCTIONS.

DANGER - RISK OF SHOCK - DISCONNECT POWER BEFORE INSTALLATION! Please read all instructions before installation.

- Keep these instructions for future reference.
- Must be installed by a qualified electrician in accordance with national and local standards. Designplan is not responsible for fixtures installed without regard to these standards.
- Unauthorized alterations or tampering of product voids warranty.
- The main power connection must be in accordance with local electrical codes.
- Suitable for OUTDOOR applications.



ATTENTION: **For In-Grade** - It is the contractor's responsibility to seal the conduit with "Great Stuff" aerosol seal that prevents water and moisture penetration for ultimate protection. Contractor **MUST** use gel-filled wire nuts.

Maintenance

Scheduled maintenance must be carried out once a year on all lighting devices, regardless of appliance class and type of use. It must include the following operations:

- Periodically clean fixtures to remove dirt from gratings and screw heads.
- Check tightness of screws on various parts of the device.
- Check that all cable glands and cables are intact and tight. Check that the glass or plastic lens is intact, and replace it if broken or damaged.
- The internal components such as the ballast, driver, washers and screws must not show clear signs of oxidation or rust. Clear traces of rust and oxidation will indicate the presence of water inside the device.
- In the case of damage, the components must be replaced by original components or spare parts.

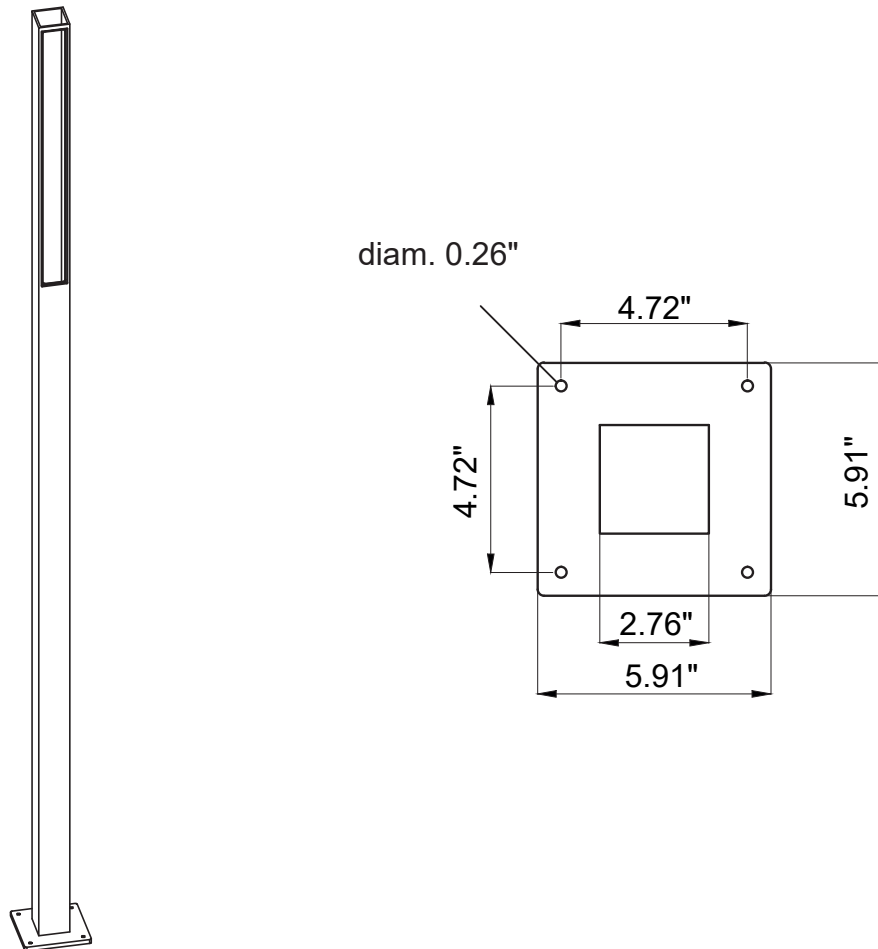

GENERAL INSTRUCTION

The safety of fixture is guaranteed only when it is used in accordance with following instructions, therefore it is necessary to keep them. Eventual tampering, transformations of fixture and wrong installations cause the loss of every guarantee. Before carrying out any installation or maintenance procedure, switch the electric power off. THE FIXTURE IS IN CLASS I AND THEREFORE IT CAN BE USED ONLY FOR INSTALLATION WITH EARTH LINE.

MAINTENANCE

In case of replacement of the bright source you have to respect the parameters indicated inside mark in the fixture.

In case of breaking or crack of diffuser to call our company in order to make the exact replacement.

It is important to clean the fitting in order to avoid dirty deposit on the rubber closing basket and inside the fixture.

To clear the glass not use abrasive products.

In case of restitution of the material, after authorization by F.LLI FRANCESCONI & C. SRL, you have to turn back the fixture in our company free of charge on our part; the fixture not to be disassembled and you have to leave out a part of feeder (min. 10 cm.) near the cable blocker.

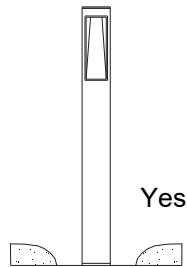

Yes

FIG.C

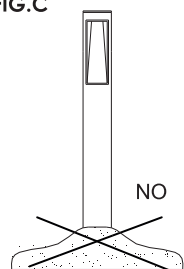

NO

Fixing in the ground

To make a plint to fix the product base. To make fixing holes (A) and to put the tirax. To avoid direct contact between base of fitting pole with the ground in order to avoid any contact between aluminium parts and humidity and chemical element (C).

To clear periodically metallic parts that may be in contact with ground. Never install the fitting in the ground with wrong incline that may be the cause of dirty deposit and permanent submersion. The fitting parts are damaged owing to stagnation and aggressive chemical elements.

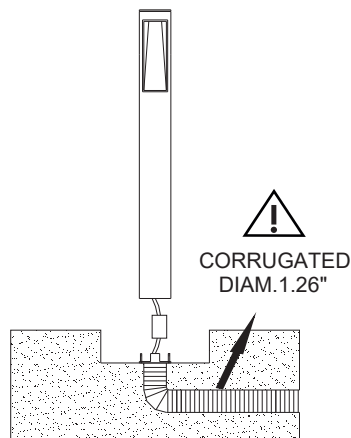

CORRUGATED
DIAM.1.26"

Feeders

After fixing the base in the ground to connect the cable out of the product to feeder by water tight dividing-connection with IP67 minimum.

To be sure that product is fixed correctly to the base and screws positioned correctly. We suggest you a correct clearing cycle on the product to guarantee a perfect working during the time.