



INSTRUCTIONS PERTAINING TO RISK OF FIRE OR INJURY TO PERSONS. READ ALL INSTRUCTIONS. IMPORTANT SAFETY INSTRUCTIONS. SAVE THESE INSTRUCTIONS.

DANGER - RISK OF SHOCK - DISCONNECT POWER BEFORE INSTALLATION! Please read all instructions before installation.

- Keep these instructions for future reference.
- Must be installed by a qualified electrician in accordance with national and local standards. Designplan is not responsible for fixtures installed without regard to these standards.
- Unauthorized alterations or tampering of product voids warranty.
- The main power connection must be in accordance with local electrical codes.
- Suitable for OUTDOOR applications.

Electrical Connections:

- LED lights must be **connected in parallel** respecting polarities.
- **CHOOSE POWER SUPPLY ACCORDINGLY.** Please consider the voltage through which fixtures are fed as well as the max power consumption.
- **Connect power only if all the fixtures are connected.**
- The power supplies **MUST** be installed in aerated rooms, far from heat sources. Overworking or lack of air circulation will not permit natural dissipation.
- Use only Class 2 type electronic power supply.
- Never use switches on secondary circuit.



IP68 (to 9.84 ft)

ATTENTION: For In-Grade - It is the contractor's responsibility to seal the conduit with "Great Stuff" aerosol seal that prevents water and moisture penetration for ultimate protection. Contractor **MUST** use gel-filled wire nuts.

Maintenance

Scheduled maintenance must be carried out once a year on all lighting devices, regardless of appliance class and type of use. It must include the following operations:

- Periodically clean fixtures to remove dirt from gratings and screw heads.
- Check tightness of screws on various parts of the device.
- Check that all cable glands and cables are intact and tight. Check that the glass or plastic lens is intact, and replace it if broken or damaged.
- The internal components such as the ballast, driver, washers and screws must not show clear signs of oxidation or rust. Clear traces of rust and oxidation will indicate the presence of water inside the device.
- In the case of damage, the components must be replaced by original components or spare parts.

FIXTURE DIMENSIONS:

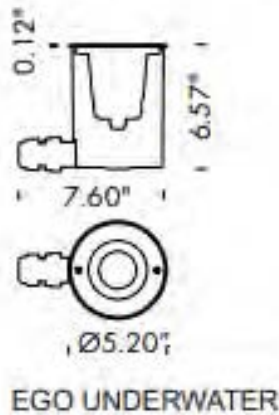

EGO UNDERWATER

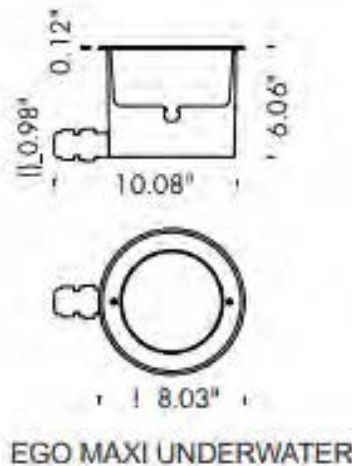

EGO MAXI UNDERWATER

All luminaires have to undergo regular maintenance (CEI 64-8 standards) according to the following steps:

- clear periodically the luminaires to avoid dirty deposit
- check the fastening of the screws
- inspect cables and cable glands for any possible damage
- check the fastening of cable glands
- check if seals are working order
- defect or damaged must be replaced before switching the luminaire on. Use original spare parts only
- it is important to carry out luminaire maintenance at each bulb substitution or at least once per year
- any improper use installation, any tampering, any unauthorized modification of the luminaire causes the immediate expiry of any claim against the manufacturer
- should Francesconi allow the return of a luminaire for technical inspection or tests, they must be returned with a piece of wiring cable (7.87") connected to the luminaire and complete with the connection made by the installer

HOW TO INSTALL THE LUMINAIRE

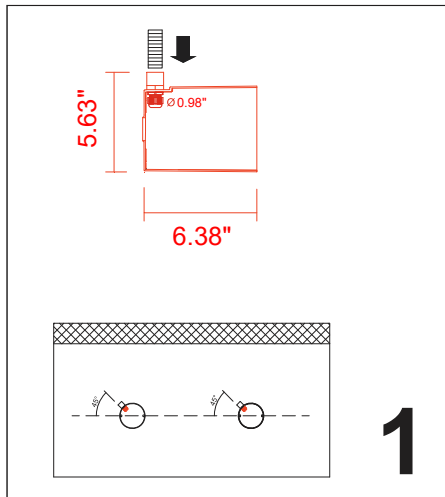

GB

To put the junction box in the concrete. Remember to put in the relative housing of junction box a corugate tube diameters 0.98" to guarantee correct assembling of product.
To put junction box in order to alignment of screws are horizontal.

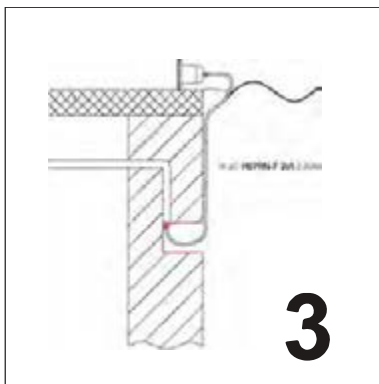
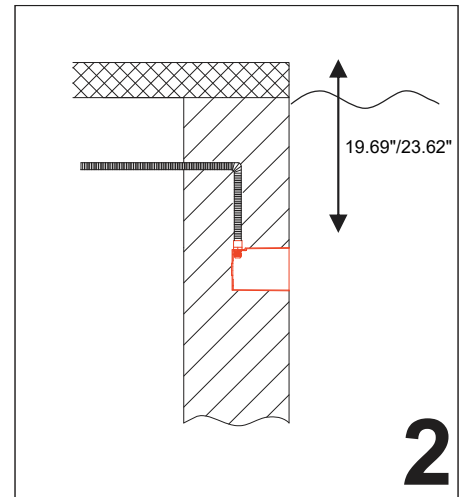

Fixing product

After fixing the product to put cable supplied in relative plastic cable-blocker and then to close it. It is important to close cable blocker correctly to guarantee watertight of fitting.
We suggest to keep 15.75"/19.69" of cable in junction box in order to draw up the fitting easily for eventual maintenance.

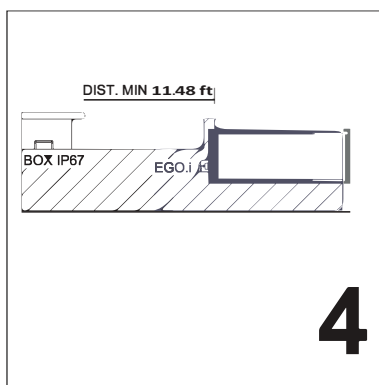

- to install in remote position, minimum 11.48 feet of distance from water.
- control gear has IP67 of protection and it must be kept dry; temporarily (max. 30minutes) it resists to eventual submersion.

- It is the contractor's responsibility to caulk around the edges between the fixture and the mounting surface, to satisfy wet label requirements.

