



**INSTRUCTIONS PERTAINING TO RISK OF FIRE OR INJURY TO PERSONS. READ ALL INSTRUCTIONS. IMPORTANT SAFETY INSTRUCTIONS. SAVE THESE INSTRUCTIONS.**

**DANGER - RISK OF SHOCK - DISCONNECT POWER BEFORE INSTALLATION! Please read all instructions before installation.**

- Keep these instructions for future reference.
- Must be installed by a qualified electrician in accordance with national and local standards. Designplan is not responsible for fixtures installed without regard to these standards.
- Unauthorized alterations or tampering of product voids warranty.
- The main power connection must be in accordance with local electrical codes.
- Suitable for INDOOR applications.
- DO NOT INSTALL INSULATION WITHIN 3.0" (76 mm) OF ANY PART OF THE LUMINAIRE.



## Electrical Connections:

- LED lights must be **connected in series** respecting polarities.
- **CHOOSE POWER SUPPLY ACCORDINGLY.** Please consider the voltage through which fixtures are fed as well as the max power consumption.
- **Connect power only if all fixtures are connected.**
- The power supplies **MUST** be installed in aerated rooms, far from heat sources. Overworking or lack of air circulation will not permit natural dissipation.
- The electronic power supply is current-stable, therefore it partially compensates the voltage-drop problems related to the cable length; we suggest not to exceed 100 ft.
- Use only Class 2 type electronic power supply.
- Never use switches on secondary circuit.

## Maintenance

Scheduled maintenance must be carried out once a year on all lighting devices, regardless of appliance class and type of use. It must include the following operations:

- Periodically clean fixtures to remove dirt from gratings and screw heads.
- Check tightness of screws on various parts of the device.
- Check that all cable glands and cables are intact and tight. Check that the glass or plastic lens is intact, and replace it if broken or damaged.
- The internal components such as the ballast, driver, washers and screws must not show clear signs of oxidation or rust. Clear traces of rust and oxidation will indicate the presence of water inside the device.
- In the case of damage, the components must be replaced by original components or spare parts.

# MICRO PIXL 6 RECESSED

6.2W, REMOTE 180mA

## FIXTURE DIMENSIONS:

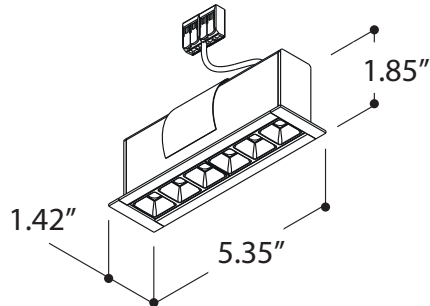

417699 INSTALLATION FRAME FOR PLASTER

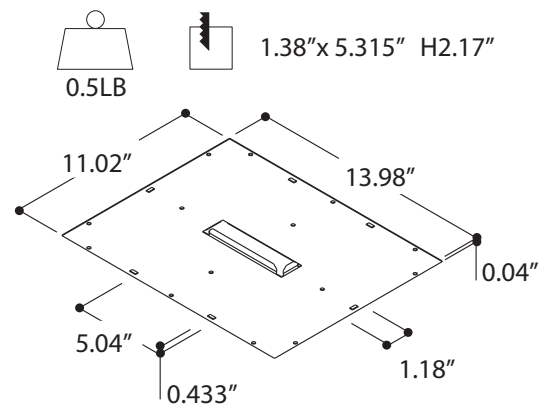

417697 INSTALLATION FRAME + BOX FOR PLASTER

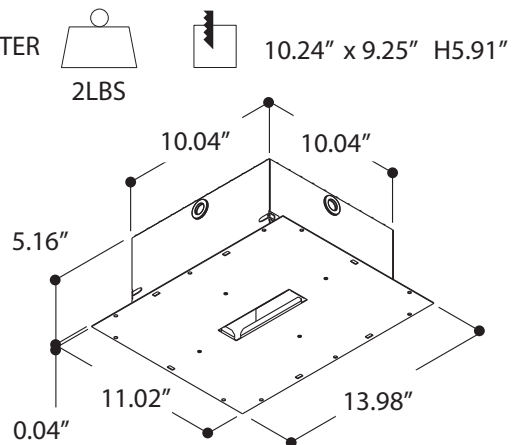

# MICRO PIXL 6 RECESSED

6.2W, REMOTE 180mA

designplan®

installation instructions

## FIXTURE INSTALLATION:

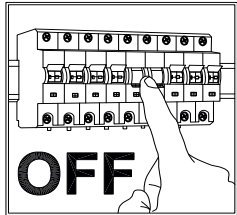

- It is the contractor's responsibility to caulk around all the edges between the fixture and the mounting surface, to satisfy wet label requirements.
- It is the contractor's responsibility to install Remote Driver in a suitable electrical enclosure.

### ① Make hole with cut-out dimensions

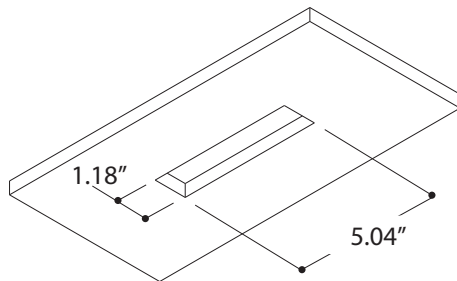

Min. ceiling thickness = 0.39"  
Max. ceiling thickness = 0.984"  
Min. installation depth = 2.17"

### ② Make electrical connection



Do not cover top of luminaire with isolation (Ta max 40°C)

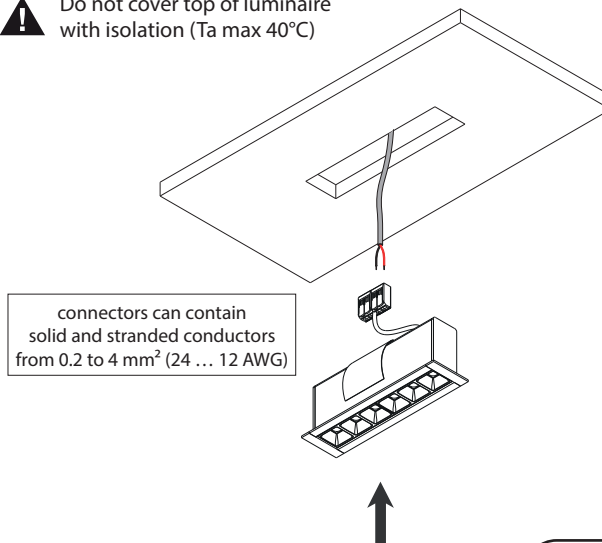

### ③ Click luminaire into hole

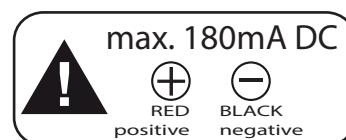

- ④ Turn on mains power supply

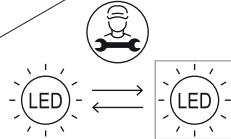
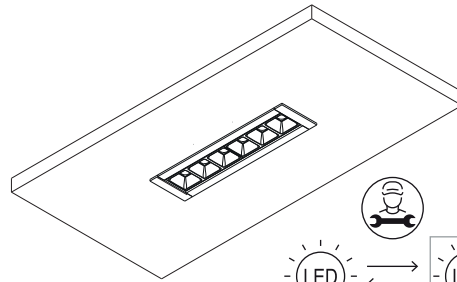

Replaceable light source by a professional

### Installation with FRAME for PLASTER (417699):

- ① Make prescribed hole in the ceiling

Minimum installation depth = 2.17"

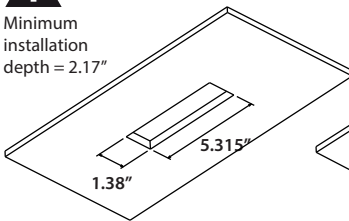

- ② Mount the plasterkit

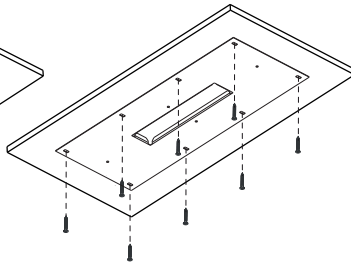

- ③ Add plaster to kit and screws  
Sand and paint afterwards

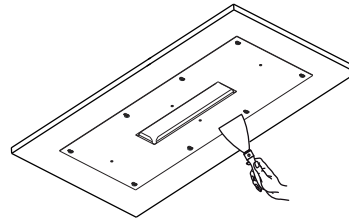

- ④ Follow step 2 from regular installation for further finishing

### Installation with FRAME + BOX for PLASTER (417697):

- ① Mount conbox in hole using screws / concrete

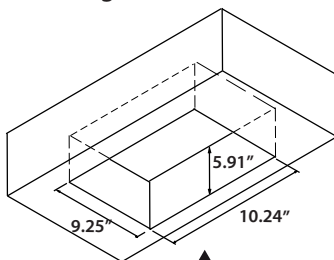

- ② Mount the plasterkit

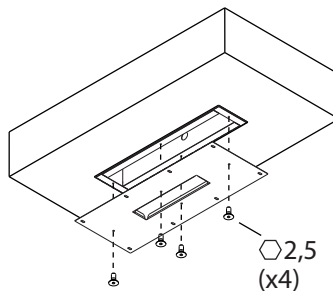

- ③ Add plaster to kit and screws  
Sand and paint afterwards

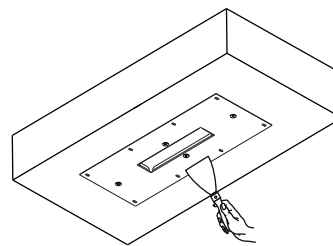

- ④ Follow step 2 from regular installation for further finishing

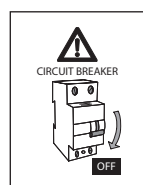

ALWAYS DISCONNECT MAINS POWER SUPPLY FROM CONVERTER BEFORE SWITCHING "ON" LED LUMINAIRES TO PREVENT HOT PLUGGING ISSUES

